

140 W USB-PD reference board with PFC + hybrid flyback combo IC XDP™ XDPS2221

REF_XDPS2221_140W1

About this document



Scope and purpose

This document presents information about the 140 W USB-PD (power delivery) reference board, using a novel **XDP™ digital power XDPS2221** for power factor correction (PFC) + hybrid flyback (HFB), CoolGaN™ device **IGLD60R190D1** as the main switch, and EZ-PD™ CCG3PA **CYPD3175** for USB-PD extended power range (EPR) control. The document includes the key waveforms and performance data.

Intended audience

Users of the 140 W reference board, design engineers of PFC + HFB converters using the XDP™ XDPS2221.

Key words

XDP™ digital power, PFC + HFB, combo controller, XDP™ XDPS2221, CoolGaN™, IGLD60R190D1, EZ-PD™ CCG3PA CYPD3175, USB-PD controller, charger, adapter.

Important notice

Important notice

“Evaluation Boards and Reference Boards” shall mean products embedded on a printed circuit board (PCB) for demonstration and/or evaluation purposes, which include, without limitation, demonstration, reference and evaluation boards, kits and design (collectively referred to as “Reference Boards”).

Environmental conditions have been considered in the design of the Evaluation Boards and Reference Boards provided by Infineon Technologies. The design of the Evaluation Boards and Reference Boards has been tested by Infineon Technologies only as described in this document. The design is not qualified in terms of safety requirements, manufacturing and operation over the entire operating temperature range or lifetime.

The Evaluation Boards and Reference Boards provided by Infineon Technologies are subject to functional testing only under typical load conditions. Evaluation Boards and Reference Boards are not subject to the same procedures as regular products regarding returned material analysis (RMA), process change notification (PCN) and product discontinuation.

Evaluation Boards and Reference Boards are not commercialized products, and are solely intended for evaluation and testing purposes. In particular, they shall not be used for reliability testing or production. The Evaluation Boards and Reference Boards may therefore not comply with CE or similar standards (including but not limited to the EMC Directive 2004/EC/108 and the EMC Act) and may not fulfill other requirements of the country in which they are operated by the customer. The customer shall ensure that all Evaluation Boards and Reference Boards will be handled in a way which is compliant with the relevant requirements and standards of the country in which they are operated.

The Evaluation Boards and Reference Boards as well as the information provided in this document are addressed only to qualified and skilled technical staff, for laboratory usage, and shall be used and managed according to the terms and conditions set forth in this document and in other related documentation supplied with the respective Evaluation Board or Reference Board.

It is the responsibility of the customer’s technical departments to evaluate the suitability of the Evaluation Boards and Reference Boards for the intended application, and to evaluate the completeness and correctness of the information provided in this document with respect to such application.

The customer is obliged to ensure that the use of the Evaluation Boards and Reference Boards does not cause any harm to persons or third-party property.

The Evaluation Boards and Reference Boards and any information in this document is provided “as is” and Infineon Technologies disclaims any warranties, express or implied, including but not limited to warranties of non-infringement of third-party rights and implied warranties of fitness for any purpose, or for merchantability.

Infineon Technologies shall not be responsible for any damages resulting from the use of the Evaluation Boards and Reference Boards and/or from any information provided in this document. The customer is obliged to defend, indemnify and hold Infineon Technologies harmless from and against any claims or damages arising out of or resulting from any use thereof.

Infineon Technologies reserves the right to modify this document and/or any information provided herein at any time without further notice.

Safety precautions

Safety precautions

Note: Please note the following warnings regarding the hazards associated with development systems.

Table 1 Safety precautions

	<p>Warning: The DC-link potential of this board is up to 1000 V DC. When measuring voltage waveforms by oscilloscope, high-voltage differential probes must be used. Failure to do so may result in personal injury or death.</p>
	<p>Warning: The evaluation or reference board contains DC bus capacitors, which take time to discharge after removal of the main supply. Before working on the drive system, wait five minutes for capacitors to discharge to safe voltage levels. Failure to do so may result in personal injury or death. Darkened display LEDs are not an indication that capacitors have discharged to safe voltage levels.</p>
	<p>Warning: The evaluation or reference board is connected to the grid input during testing. Hence, high-voltage differential probes must be used when measuring voltage waveforms by oscilloscope. Failure to do so may result in personal injury or death. Darkened display LEDs are not an indication that capacitors have discharged to safe voltage levels.</p>
	<p>Warning: Remove or disconnect power from the drive before you disconnect or reconnect wires, or perform maintenance work. Wait five minutes after removing power to discharge the bus capacitors. Do not attempt to service the drive until the bus capacitors have discharged to zero. Failure to do so may result in personal injury or death.</p>
	<p>Caution: The heatsink and device surfaces of the evaluation or reference board may become hot during testing. Hence, necessary precautions are required while handling the board. Failure to comply may cause injury.</p>
	<p>Caution: Only personnel familiar with the drive, power electronics and associated machinery should plan, install, commission and subsequently service the system. Failure to comply may result in personal injury and/or equipment damage.</p>
	<p>Caution: The evaluation or reference board contains parts and assemblies sensitive to electrostatic discharge (ESD). Electrostatic control precautions are required when installing, testing, servicing or repairing the assembly. Component damage may result if ESD control procedures are not followed. If you are not familiar with ESD control procedures, refer to the applicable ESD protection handbooks and guidelines.</p>
	<p>Caution: A drive that is incorrectly applied or installed can lead to component damage or reduction in product lifetime. Wiring or application errors such as undersizing the motor, supplying an incorrect or inadequate AC supply, or excessive ambient temperatures may result in system malfunction.</p>
	<p>Caution: The evaluation or reference board is shipped with packing materials that need to be removed prior to installation. Failure to remove all packing materials that are unnecessary for system installation may result in overheating or abnormal operating conditions.</p>

Table of contents

About this document	1
Important notice	2
Safety precautions	3
Table of contents	4
1 XDP™ XDPS2221 overview	5
1.1 Product highlights	5
1.2 PFC control features.....	5
1.3 HFB control features	5
1.4 IC pin layout.....	5
1.5 Main customer benefits.....	6
1.5.1 Low bill of materials.....	6
1.5.2 High system performance.....	6
1.5.3 Unique controller in the market	6
2 Board hardware	7
2.1 Overview	7
2.1.1 Input specifications.....	7
2.1.2 Output specifications.....	8
2.1.3 Key components	8
2.1.4 Board and PCB information	8
2.2 Board system	8
2.2.1 Main power board	9
2.2.2 V _{cc} board	12
2.2.3 EPR board	13
3 System performance	14
3.1 Test equipment	14
3.2 Key waveforms	14
3.3 PFC performance.....	15
3.4 HFB performance	17
3.5 System performance	20
3.5.1 Efficiency and standby power.....	20
3.5.2 X-capacitor discharge	21
3.5.3 EMI	22
3.5.4 Thermal measurement	25
4 Appendices	27
4.1 Bills of materials of the boards	27
4.2 Information on the magnetic devices.....	31
References	35
Revision history	36
Disclaimer	37

1 XDP™ XDPS2221 overview

The XDP™ XDPS2221 controller is a highly integrated device including the valley-switching PFC controller, the HFB (asymmetrical half-bridge) controller and three gate drivers for the main switches. The internal handshaking between the PFC and HFB controller and the adaptive bus voltage setting make this controller a perfect fit for applications with wide AC input and wide output voltage range, such as USB-PD adapters and battery chargers. While detailed information about this control IC can be found in the product datasheet [1], here is a short summary of the product highlights, the main features, the IC pin layout and the main benefits for the customer.

1.1 Product highlights

- Digital combo controller for PFC and HFB in DSO-14 (150 mil) package
- Novel zero-voltage switching (ZVS) HFB topology for ultra-high system efficiency
- Integrated gate drivers supporting GaN and Si switches
- 600 V high-voltage start-up cell for fast V_{CC} charging and active X-capacitor discharge
- Burst mode operation for lowest no-load standby power
- Adaptive PFC bus voltage and PFC enable/disable control to maximize average and light load efficiency
- Configurable parameters for protection modes and system performance
- Pb-free lead plating, halogen-free (according to IEC61249-2-21), RoHS compliant

1.2 PFC control features

- Configurable PFC QRM operation for improved average efficiency
- Pulse skipping for improved light load efficiency
- Automatic PFC disable/enable control depending on operating conditions
- Adaptive PFC bus voltage level following operating conditions

1.3 HFB control features

- Peak current mode control for robust and fast input and load control
- ZVS operation of high-side and low-side switch, with ZVS pulse insertion in discontinuous conduction mode (DCM)
- Configurable multi-mode operation for improved average and light load efficiency

1.4 IC pin layout

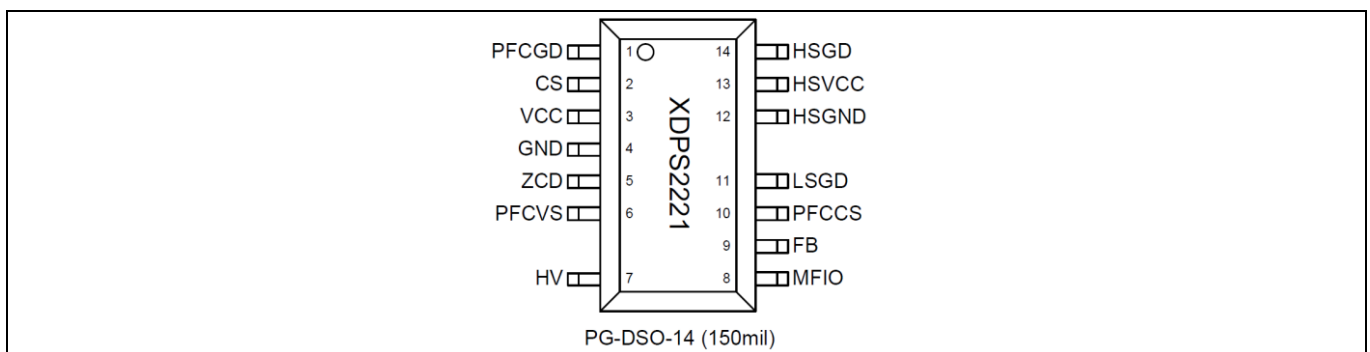

Figure 1 XDP™ XDPS2221 pin layout

1.5 Main customer benefits

1.5.1 Low bill of materials

- PFC + HFB control with gate drivers in one 14-pin DSO package
- Integrated gate drivers for direct driving of both CoolMOS™ and CoolGaN™
- Integrated start-up cell for V_{CC} initial charge-up and X-capacitor discharge functionality
- Potential transformer size reduction compared to other flyback topologies

1.5.2 High system performance

- High system efficiency
- High power density design
- Low standby power

1.5.3 Unique controller in the market

- The best suitable controller for applications with wide AC input and wide output voltage range, such as USB-PD EPR adapters and battery chargers
- Embedded digital core supporting configurable parameters for optimum system performance
- Ease of design, enabling platform design approach by using one controller for multiple designs and applications

Board hardware

2 Board hardware

2.1 Overview

The 140 W USB-PD power charger reference board REF_XDPS2221_140W1 uses the XDP™ digital combo controller XDPS2221, the CoolGaN™ device IGLD60R190D1 and the EZ-PD™ controller CCG3PA CYPD3175. It targets applications of USB-PD charger adapters, such as smartphones and mobile computers, with a wide input range and a wide output voltage range. **Figure 2** shows the top view of the complete board system, consisting of a main power board, a V_{CC} daughter board and an EPR board. The AC input connection points are X1 and X2 at the bottom-left corner, while the board output is the Type-C connector at the upper-right corner.



Figure 2 The board system

2.1.1 Input specifications

Table 2 lists the board input specifications.

Table 2 Electrical characteristics: AC input

Parameter	Symbol	Value			Unit	Condition
		Min.	Typ.	Max.		
AC voltage	V _{AC}	90		264	V _{rms}	Maximum range
		100		240	V _{rms}	Operating range
AC frequency	f _{AC}	47		63	Hz	
Power factor			0.98			At 115 V AC, full load
			0.95			At 230 V AC, full load
Brown-in			85		V	
Brown-out			75		V	
X-capacitor discharge time				2	s	X2 capacitance at 330 nF
Conducted EMI		-3			dB	EN 55022 class B

Board hardware

2.1.2 Output specifications

Table 3 lists the board output specifications.

Table 3 Electrical characteristics: output specifications

Parameter	Symbol	Value			Unit	Condition
		Min.	Typ.	Max.		
Output voltage	V_{out}		5		V	Mean value of the standard fixed USB-PD EPR voltages, at 115 and 230 V AC input
			9		V	
			15		V	
			20		V	
			28		V	
Output current	I_{out}	0	3		A	$V_{out} = 5\text{ V}$
		0	5		A	$V_{out} > 5\text{ V}$
Start-up time				1	s	5 V V_{out} at cold start-up

2.1.3 Key components

The following Infineon components are used on the board.

Table 4 Key components

Item	Component
PFC + HFB controller	XDP™ XDPS2221
USB-PD controller	EZ-PD™ CCG3PA CYPD3175
PFC and HFB switches	IGLD60R190D1
SR MOSFET	BSC040N10NS5
USB load switch	IRF7240
V_{cc} regulator switch	BSS169

2.1.4 Board and PCB information

Board and PCB information is summarized in the Table 5.

Table 5 Board dimensions and power density

Item	Value	Unit
Dimensions	109.5 x 38.5 x 24	mm
Power density	22.67	W/in ³
	1.38	W/cm ³
PCB	2	Layers

2.2 Board system

The adapter consists of the main power board, the V_{cc} supply daughter board and the USD-PD EPR 28 V daughter board. Both the PFC and HFB stages are controlled by the combo controller XDP™ XDPS2221, one of Infineon’s XDP™ digital controllers. At the output side, Infineon’s USB-PD EZ-PD™ controller CCG3PA CYPD3175

Board hardware

is used for the communication with the end device and output voltage management. In the following sub-chapters, the schematic of these boards is introduced, while the bill of material (BOM) of the boards can be found in [chapter 4.1](#).

2.2.1 Main power board

The schematic and PCB layout of the main board are shown in [Figure 3](#) to [Figure 8](#).

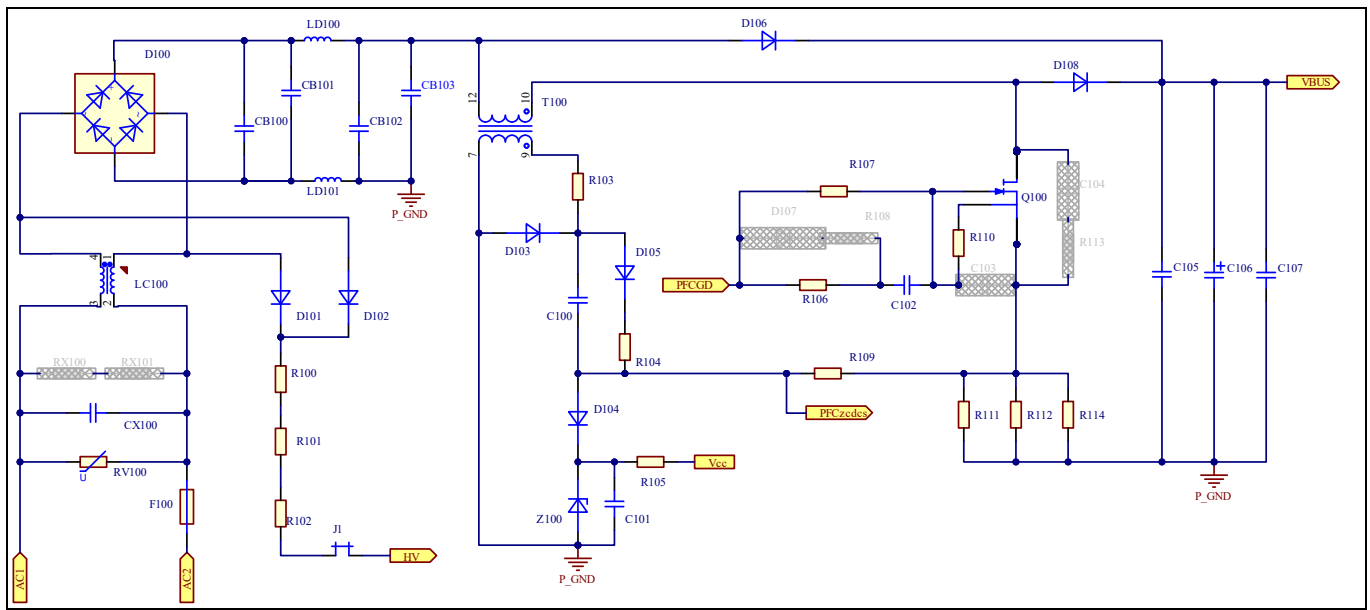

Figure 3 PFC stage schematic

Figure 3 shows the power circuitry of the AC input and PFC stage, including the input protection and EMI filter (RV100, CX100, LC100, D100, CB100, CB191, LD100, LD101, CB102 and CB103), and the start-up cell external circuit (D101, D102, R100, R101 and R102). The PFC zero-crossing detection (ZCD) and current sensing (CS) signals are combined into a single signal, PFC_{zcdcs}, which is connected to IC pin PFCCS. The voltage at the PFC auxiliary winding, which is coupled to the PFC main inductance (T100), is processed by the devices R103, D103, D105, R104, C100, D104, Z100, C101 and R105 to generate the ZCD signal, where D103 is for the negative clamping, and the network D104, Z100, C101 and R105 limits the positive voltage of the ZCD signal. Per resistor R109, the ZCD signal is effectively de-coupled from the PFC CS resistors R111, R112 and R114, which provide the CS signal to the control IC. A CoolGaN™ device is used as the main switch, Q100, and it is driven directly by the XDP™ XDPS2221 from the PFCGD pin with the external RC network (R107, R106 and C102).

Note: The grayed-out devices in the schematic are not assembled on the board. In addition, some 0 Ω resistors are prepared for easy component selection.

Board hardware

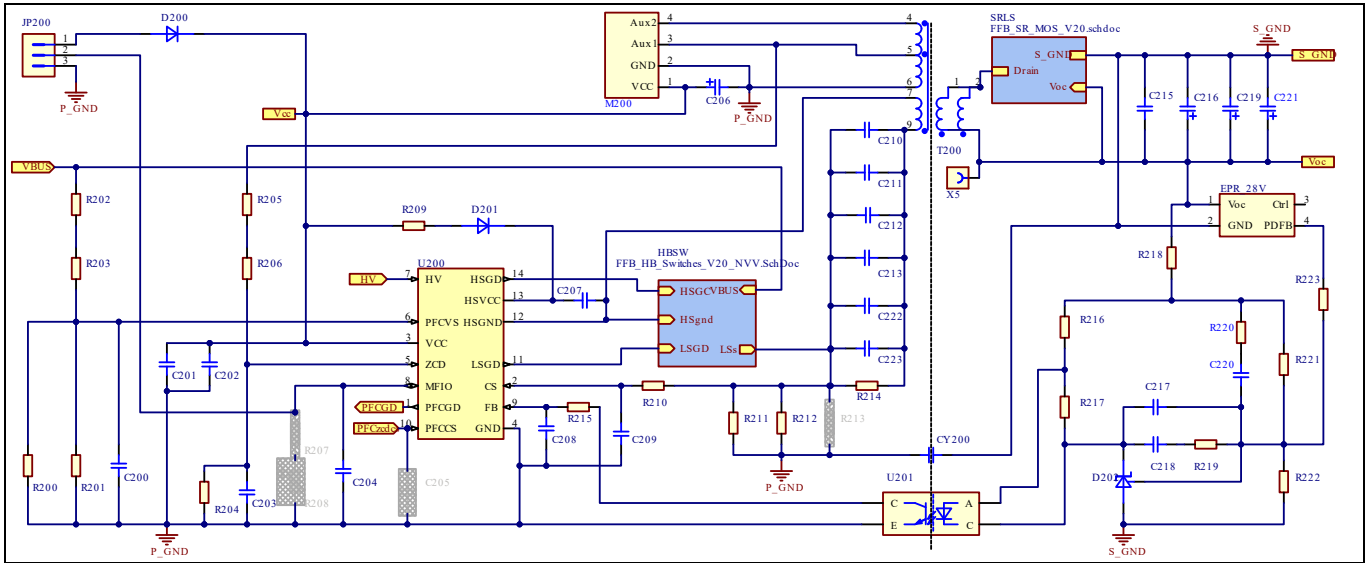

Figure 4 HFB stage schematic

The HFB is based on a half-bridge structure, which is shown in **Figure 5**. The transformer T200 primary winding is connected to the half-bridge switching node at one end and to the resonant capacitors (C201 to C223) at the other end. The shunt resistors (R211, R212) are used to sense the current through the transformer primary winding for HFB peak current regulation. For accurate switching timing, the signal from the auxiliary winding (Vaux1) is used. It generates a ZCD signal using devices R205, R206, R204 with a small filter capacitor C203. The resistors R200, R201, R202 and R203 are used for the bus voltage sensing for the PFC voltage sensing. Via the connector M200, both voltages from the auxiliary windings Aux1 and Aux2 are provided to the V_{CC} daughter board. The connector JP200 is used for the parameter configuration per the UART communication. **Figure 5** shows the schematic of the half-bridge including the gate RC network.

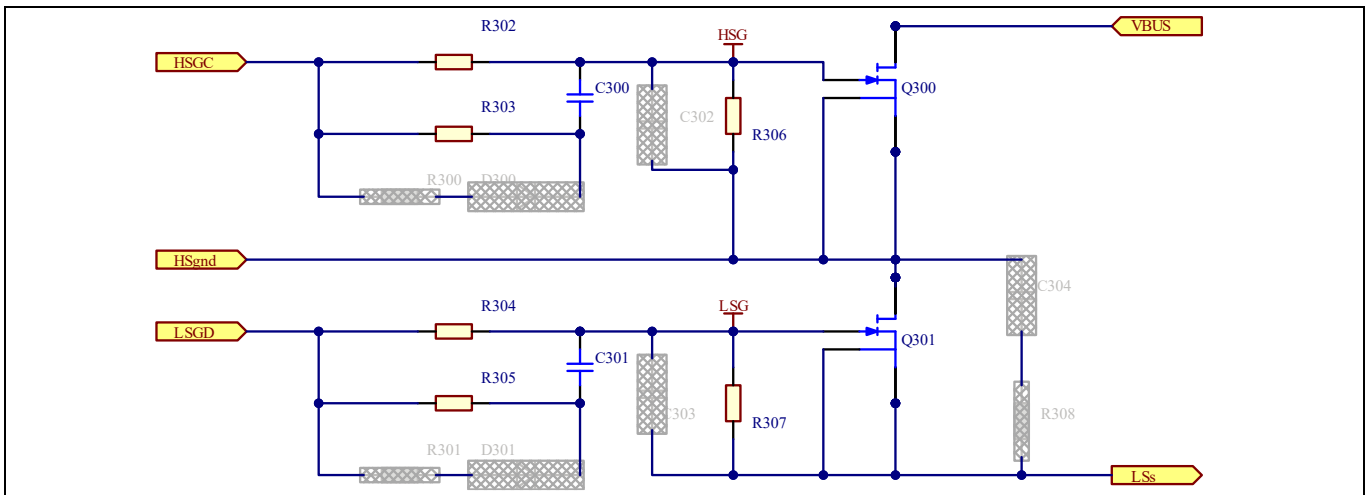

Figure 5 Half-bridge and gate RC network schematic

At the secondary side, the output voltage is rectified by the synchronous rectification circuitry, while the USB-PD daughter board controls the shunt regulator (D202) reference voltage and therefore the output voltage. The schematic of the SR daughter board is shown in **Figure 6**.

Board hardware

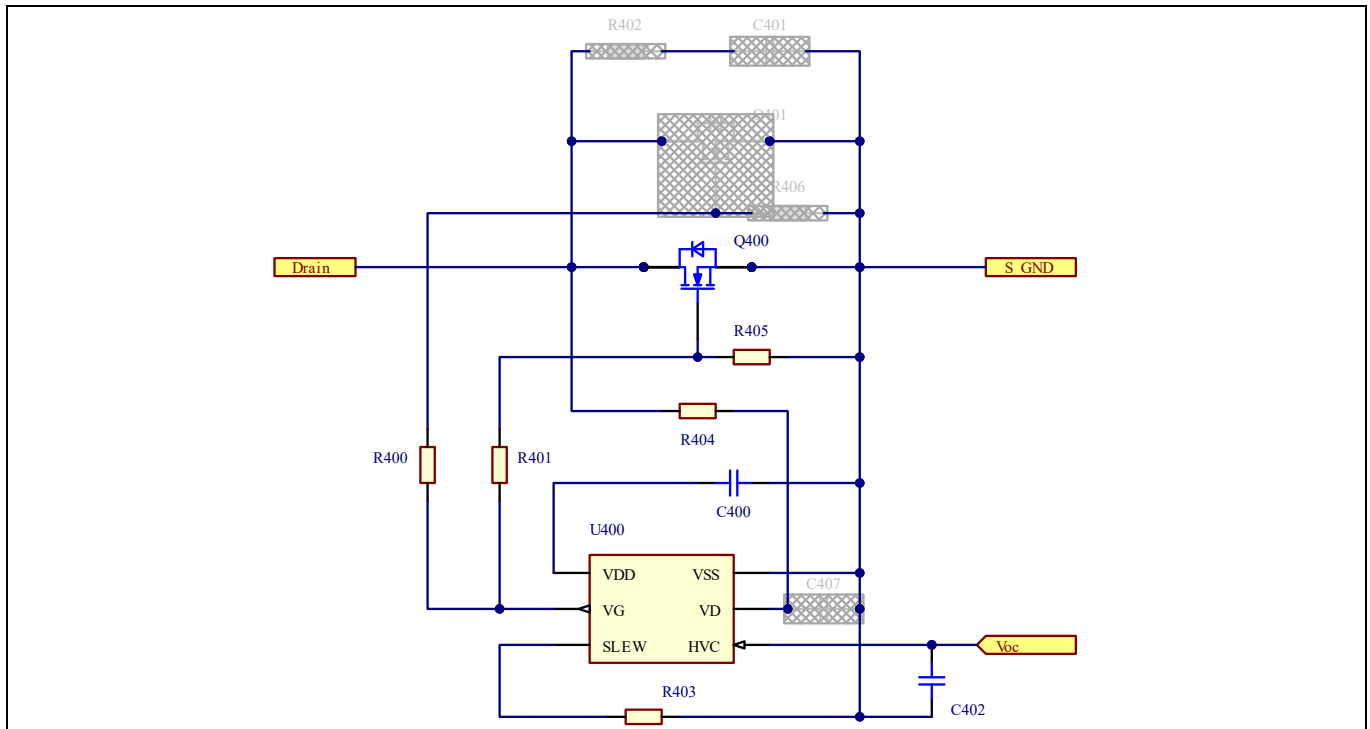

Figure 6 Synchronous rectification schematic

To keep system costs low, two-layer PCBs are used for all boards. **Figure 7** and **Figure 8** show the PCB layout of the main board.

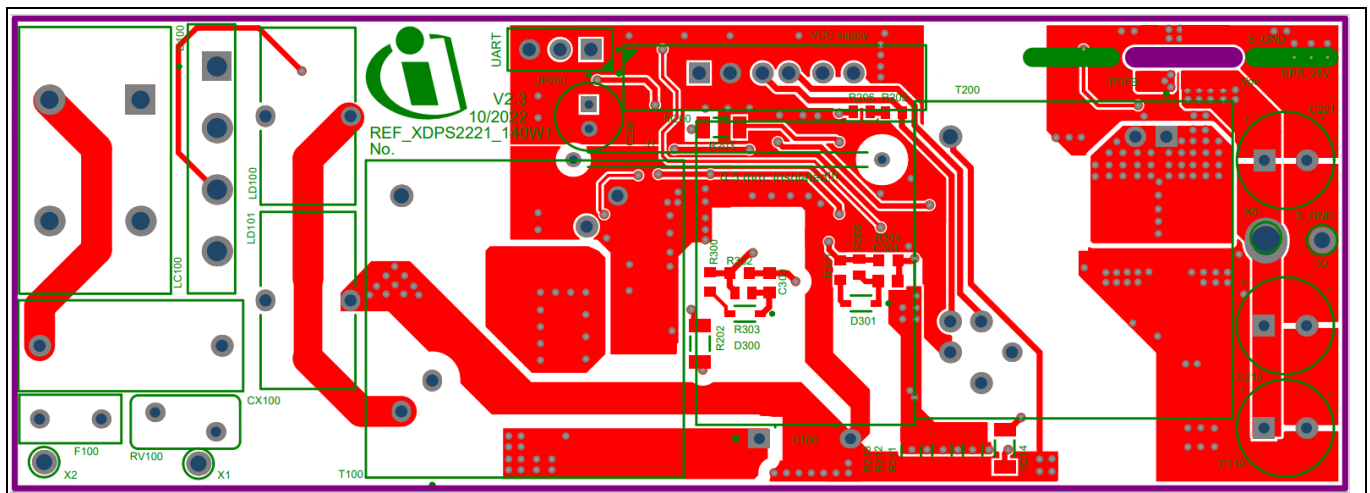

Figure 7 Main board PCB: top side

Board hardware

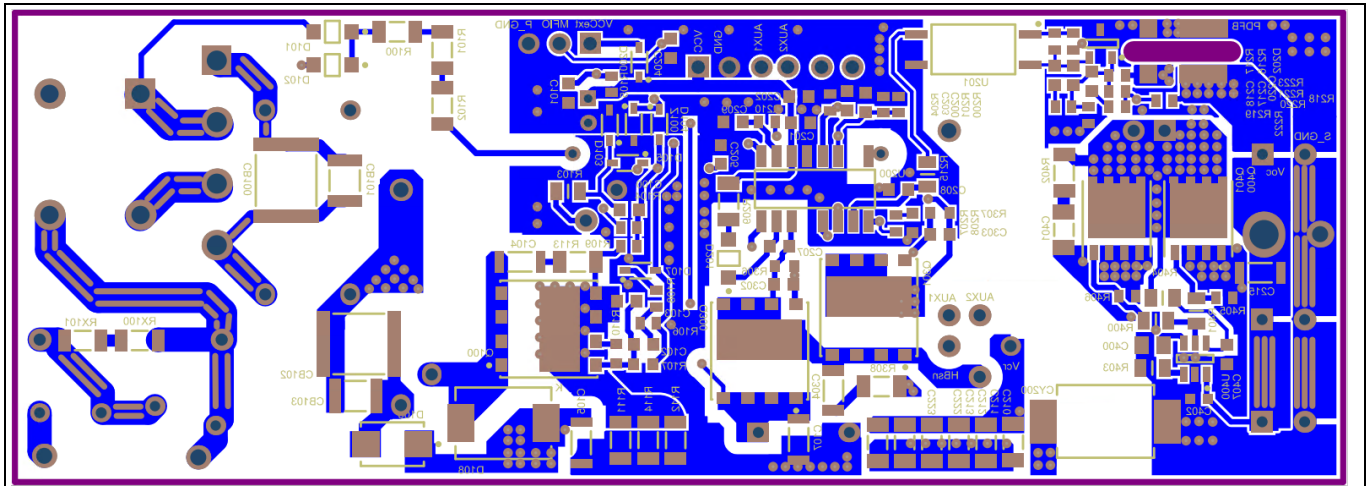

Figure 8 Main board PCB: bottom side

2.2.2 V_{CC} board

At cold start-up, the V_{CC} supply is provided via the resistors connected to the HV pin. The charging current is controlled by the start-up cell. During normal operation, the V_{CC} supply is ensured by the V_{CC} daughter board. Figure 9 shows the schematic of the V_{CC} board.

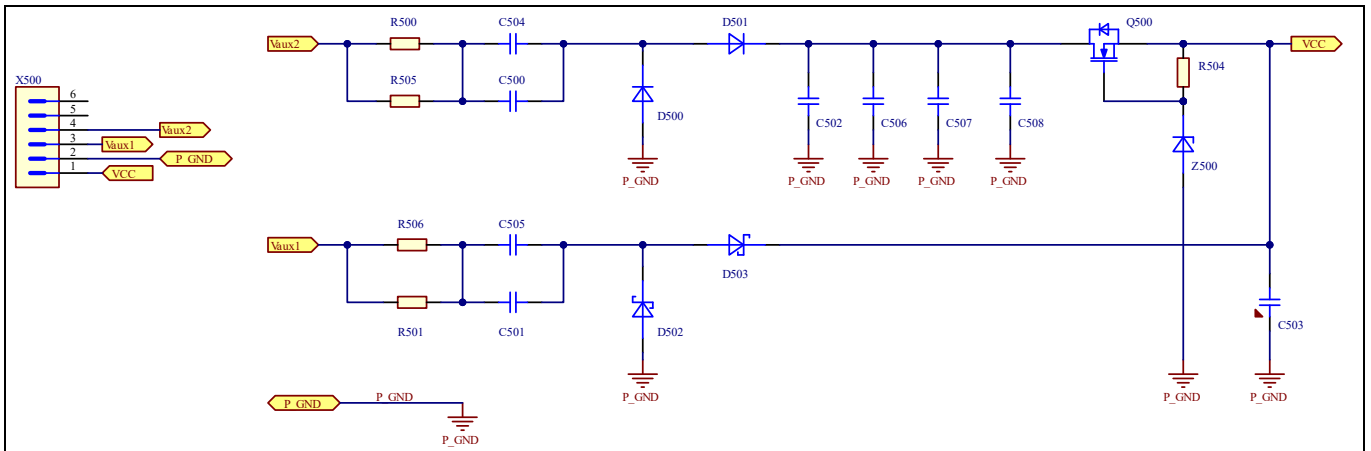

Figure 9 V_{CC} board schematic

The V_{CC} supply circuit is based on the charge-pump concept. With this concept, the IC supply is coupled to the HFB input voltage, but independent of the HFB output voltage. For efficient V_{CC} generation, two auxiliary windings are implemented. At high HFB input voltage, energy is transferred from Vaux1, while at low HFB input voltage Vaux2 is used. The PCB design for this board is shown in Figure 10.

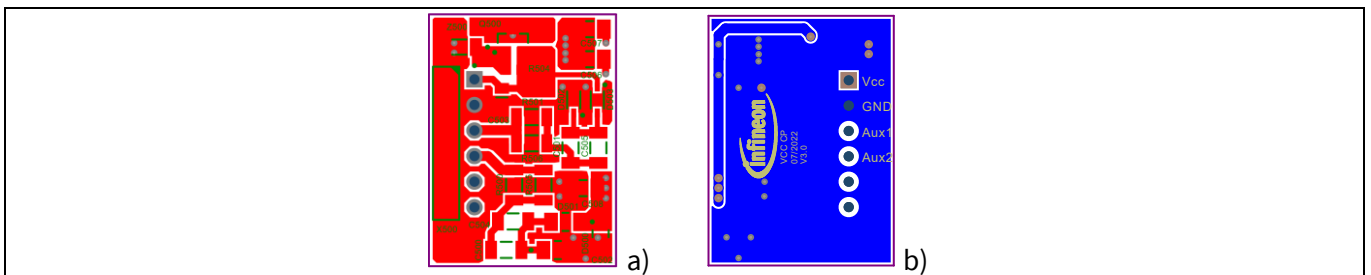

Figure 10 PCB of the V_{CC} board: a) top side and b) bottom side

Board hardware

2.2.3 EPR board

The EPR board is based on the EZ-PD™ controller CYPD3175, as shown in **Figure 11**.

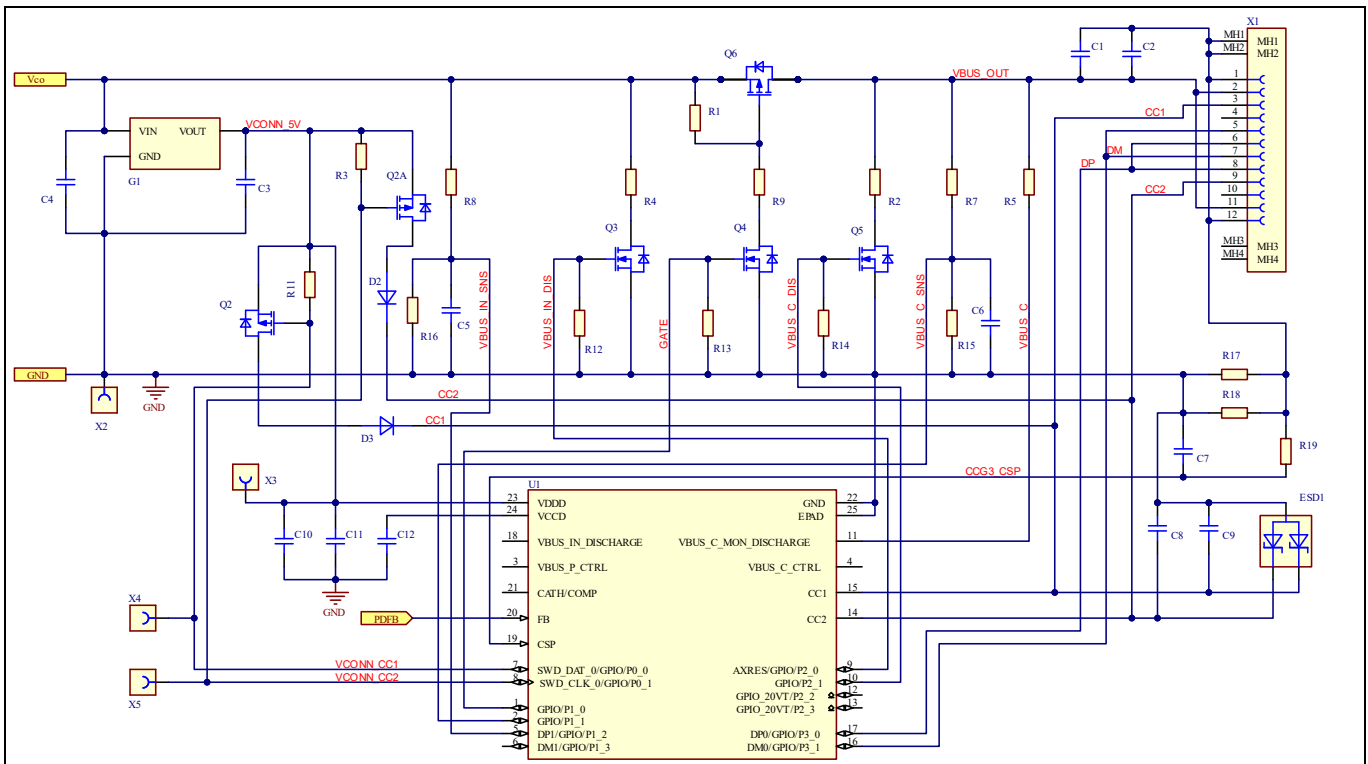

Figure 11 EPR board schematic

A linear regulator (G1) is used to generate the required supply voltage for the controller CYPD3175. The circuit consisting of Q2, Q2A, D2, D3, R3 and R11 provides the required voltage at the communication lines CC1 and CC2. The controller CYPD3175 senses both the input voltage V_{co} (V_{BUS_IN} from the point of view of the EPR board) and output voltage (V_{BUS_OUT}), where the “on” or “off” of the output voltage at the Type-C connector is controlled by the load switch Q6. The output current at the Type-C connector is sensed by shunt resistors R17 and R18, filtered by the elements of R19 and C7, and then fed to the PD control IC. The controller CYPD3175 communicates with the end device per the communication lines CC1 and CC2, sets the output voltage level of the HFB accordingly through the signal PDFB, and controls the load switch Q6 for supplying the end device. For the output voltage falling transition, the bus discharge paths before and after the safety switch (R4, Q3 and R2, Q5) may be activated by the PD controller. The PCB layout of the EPR board is shown in **Figure 12**.

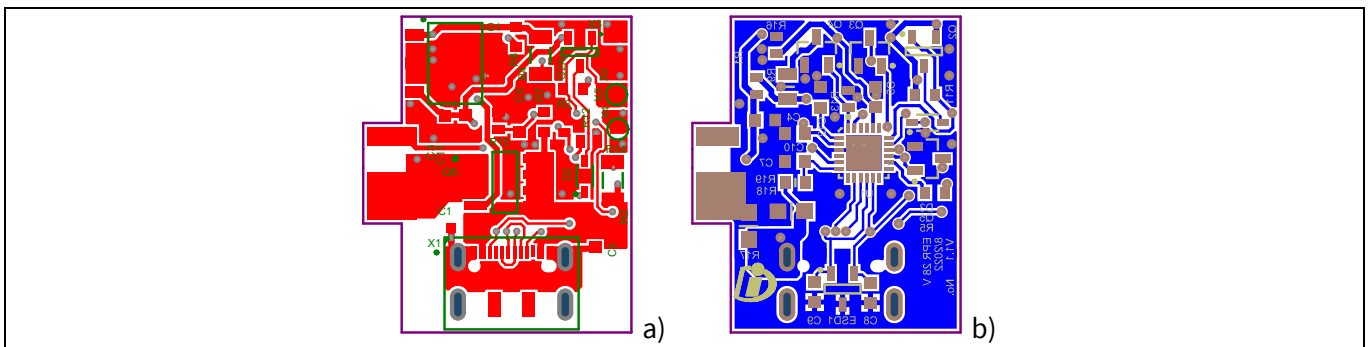

Figure 12 EPR board PCB: a) top side and b) bottom side

System performance

3 System performance

In the following sub-chapters, test equipment and key measurement results are illustrated.

3.1 Test equipment

The following equipment was used for the measurements:

- Oscilloscope: Yokogawa
- AC power source: Chroma 61504
- Electronic load: Chroma 6314A
- Digital power meter: WT3000

3.2 Key waveforms

Depending on the input and output conditions, the system operates in different modes, controlled by the controller XDP™ XDPS2221, namely:

- Burst mode
- Continuous operation

where burst mode applies only at very low load conditions.

In burst mode, depending on the output voltage and power level, the PFC stage may be kept disabled or enabled, while the HFB stage is always running in ZV-RVS mode. If PFC is enabled, it runs synchronously with the HFB. **Figure 13** a) and b) shows two typical waveforms in burst mode operation.

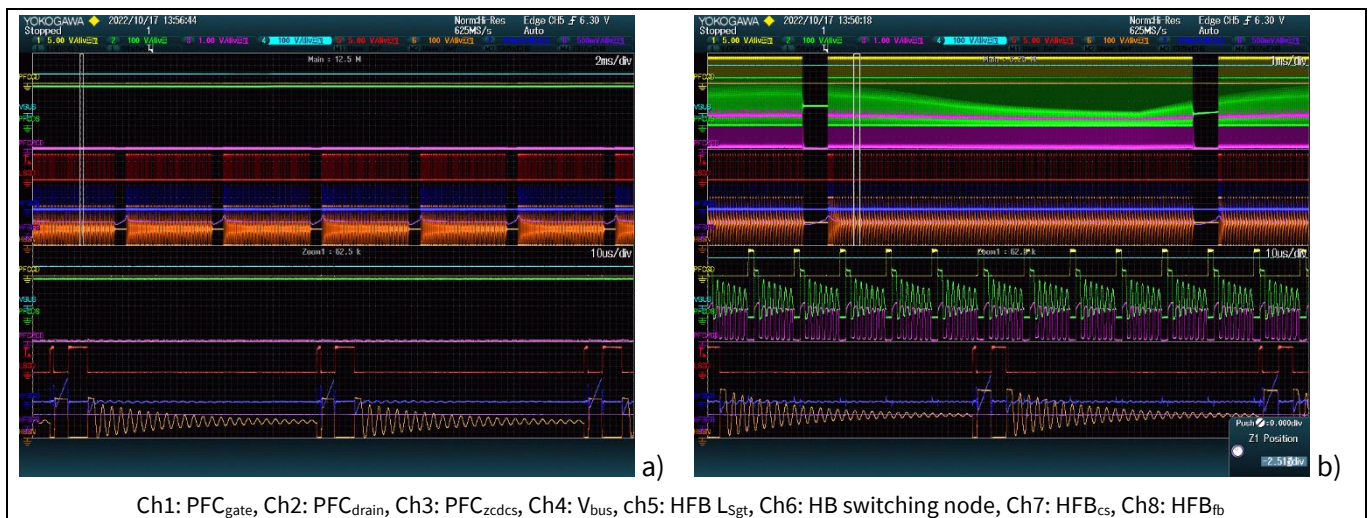

Figure 13 Waveform in burst mode operation: HFB in ZV-RVS with a) PFC disabled at 230 V input and 20 V, 0.15 A output, and b) PFC enabled at 115 V input and 28 V, 0.15 A output

Once the system exits burst mode operation, the system runs in continuous operation mode. The operation of the PFC stage depends on the input and output conditions. The HFB runs either in CRM or ZV-RVS mode depending on the output voltage and/or power. The following figures show some of the typical waveforms in continuous operation.

System performance



Figure 14 Continuous operation mode with HFB in CRM at 28 V, 5 A output: a) PFC switching at first valley at 90 V input, and b) PFC switching at third valley at 115 V input

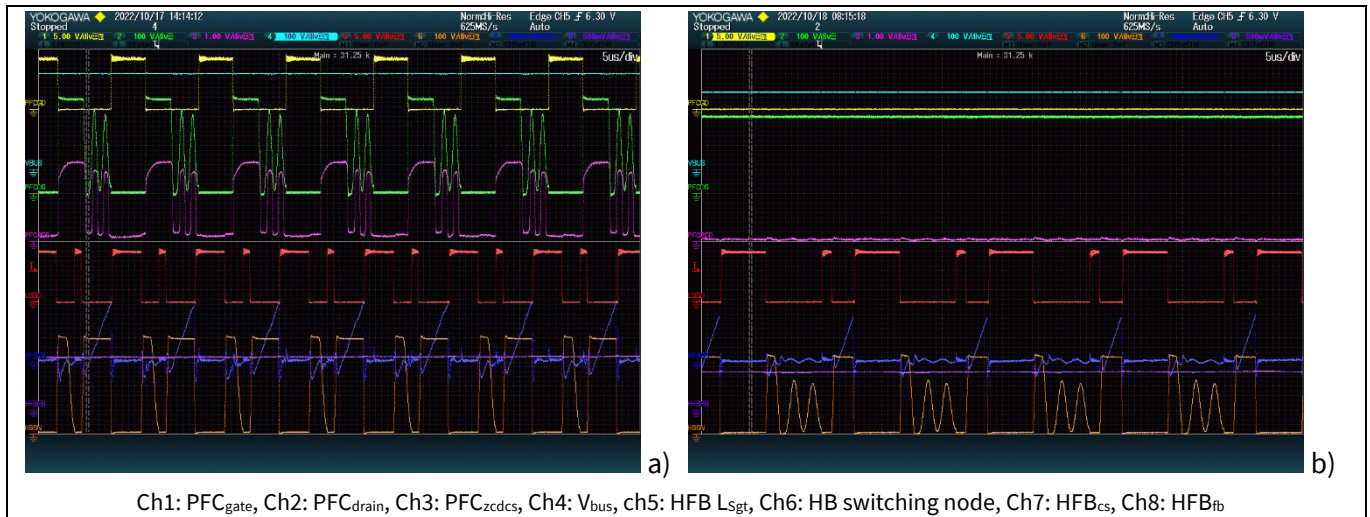

Figure 15 Continuous operation mode with HFB in ZV-RVS mode: a) PFC switching at third valley at 115 V input and 28 V 2 A output, and b) PFC disabled at 230 V, 15V 1 A output

3.3 PFC performance

Table 6 shows the PFC performance at 28 V output voltage, 100 percent and 47 percent of full-load current. At 47 percent of the full-load current, the input power is around 73 W. High power factor is achieved as shown in the measurement.

Table 6 Power factor measurement

I _{out}	V _{Ac} [V]	115	230
	47%		98.76
100%		99.25	96.54

At the same time, low harmonics current is achieved, as shown in Figure 16.

System performance

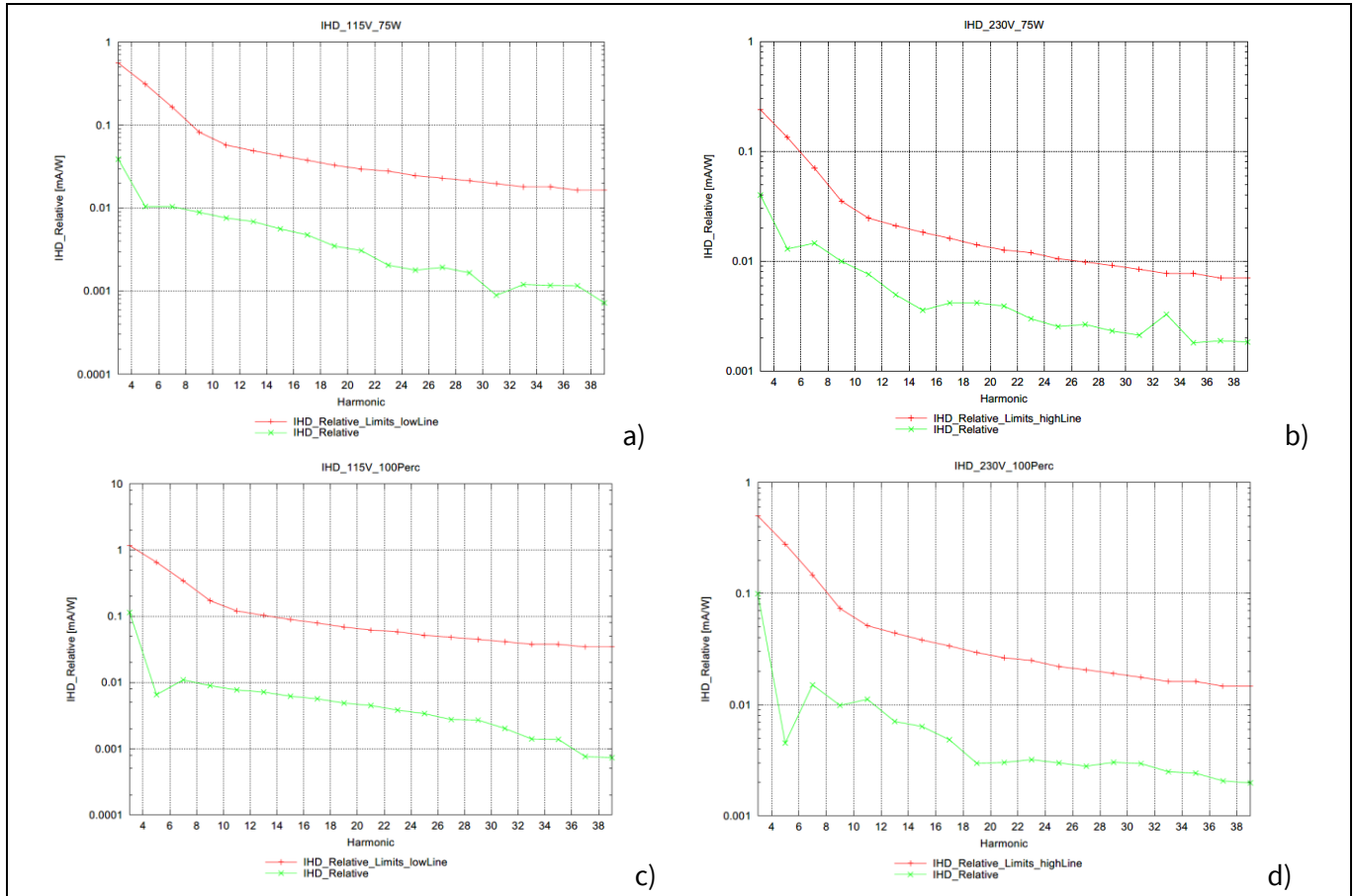

Figure 16 Harmonics current (green line) and its limit from IEC 61000-3-2 (red line): a) 115 V AC, 75 W, b) 230 V AC, 75 W, c) 115 V AC, 140 W and d) 230 V AC, 140 W

Controller XDP™ XDPS2221 has internal handshaking between the PFC and FB controller and optimized bus voltage control for the best performance. As shown in the previous waveforms (Figure 13 to Figure 15), PFC operation depends on the AC input voltage, the output voltage and the power level. This behavior is shown in Figure 17, where tests were done with the output voltage and current swapping – beginning from the bottom line to the upper line and from the left side to the right side in each line. These results show that the PFC operation can be different even with the same output condition and input condition, but it also depends on the previous condition.

Vout [V] \ Iout	Iout			
	25%	50%	75%	100%
5	OFF	OFF	OFF	OFF
9	ON	ON	ON	ON
15	ON	ON	ON	ON
20	ON	ON	ON	ON
28	ON	ON	ON	ON
20	ON	ON	ON	ON
15	ON	ON	ON	ON
9	OFF	OFF	OFF	OFF
5	OFF	OFF	OFF	OFF

a)

Vout [V] \ Iout	Iout			
	25%	50%	75%	100%
5	OFF	OFF	OFF	OFF
9	OFF	OFF	OFF	OFF
15	OFF	OFF	OFF	ON
20	ON	ON	ON	ON
28	ON	ON	ON	ON
20	OFF	OFF	ON	ON
15	OFF	OFF	OFF	ON
9	OFF	OFF	OFF	OFF
5	OFF	OFF	OFF	OFF

b)

Figure 17 Operation of the PFC stage depending on AC input voltage, output voltage and power: a) 115 V AC and b) 230 V AC

System performance

3.4 HFB performance

Figure 18 (a to e) shows the output voltage (overlapped lines in the middle) and its limits (black lines) in steady-state operation depending on the input and output conditions. The output voltage is well regulated within its limits under all conditions.

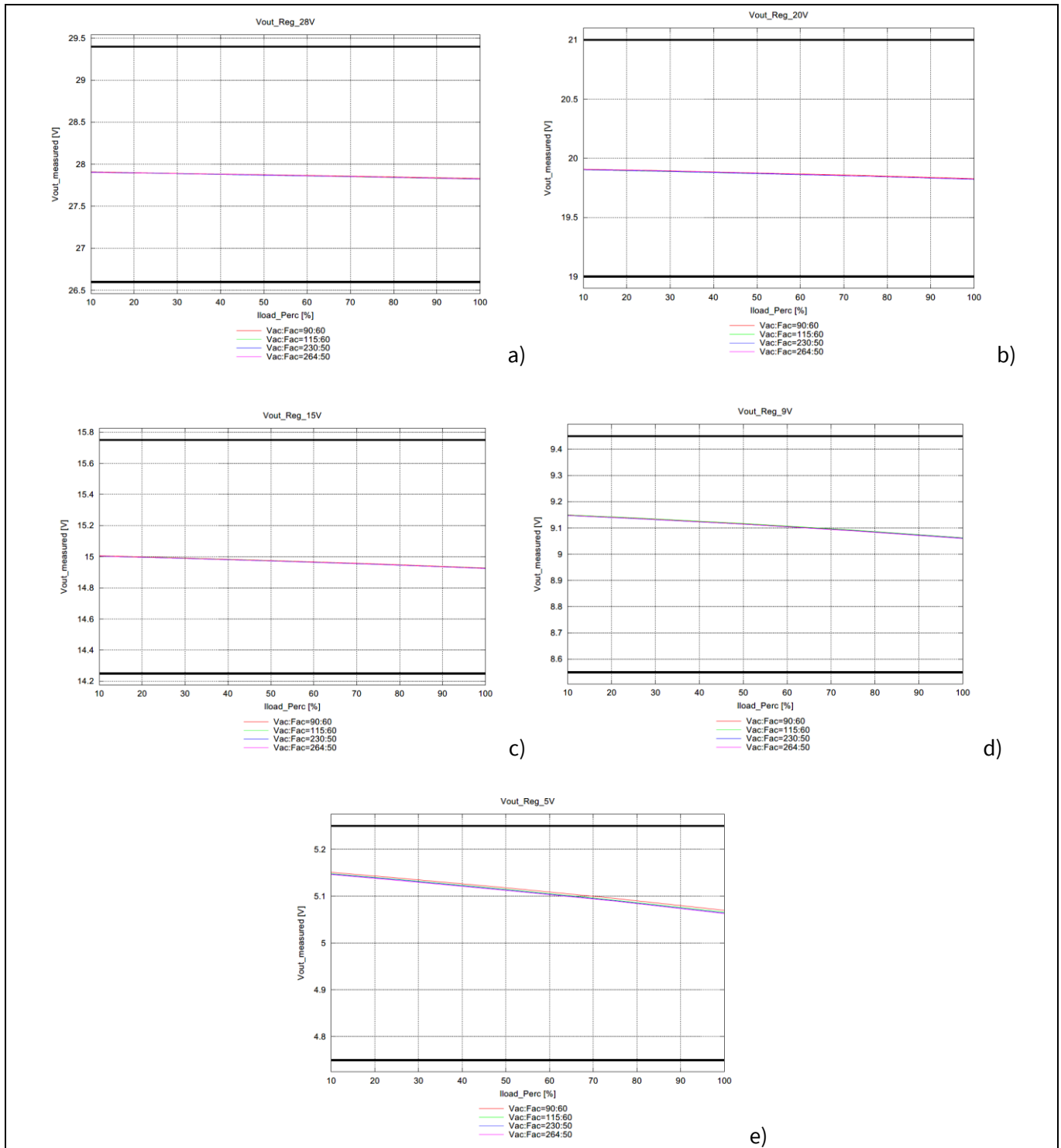

Figure 18 Output voltage in steady-state operation measured at the Type-C connector: a) 28 V, b) 20 V, c) 15 V, d) 9 V and e) 5 V

System performance

Figure 19 (a to e) shows the output voltage at dynamic load depending on the input and output conditions. It shows very high dynamic response of the HFB stage under all conditions, and the output voltage is well regulated within its limits under all conditions.

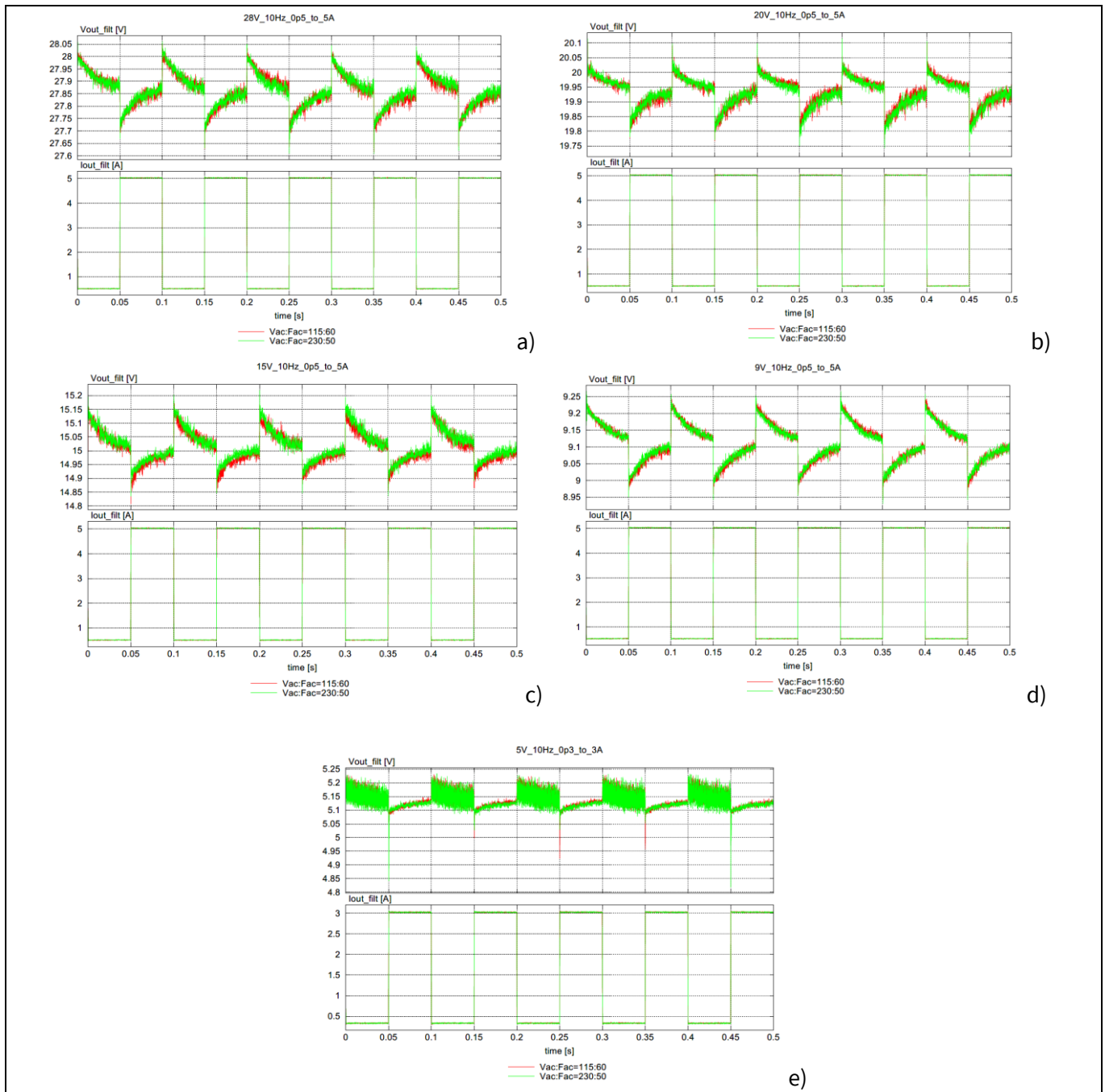

Figure 19 Output voltage at dynamic load current between 10 percent and 100 percent, measured at the HFB output capacitor: a) 28 V, b) 20 V, c) 15 V, d) 9 V and e) 5 V

The output voltage transition between 5 V and 28 V at different input and load currents is shown in Figure 20, while the time from 5 V to other voltage levels is demonstrated in Figure 21 and from other voltage levels to 5 V in Figure 22. Smooth voltage transition is shown, and the transition time is within the USB-PD requirements.

System performance

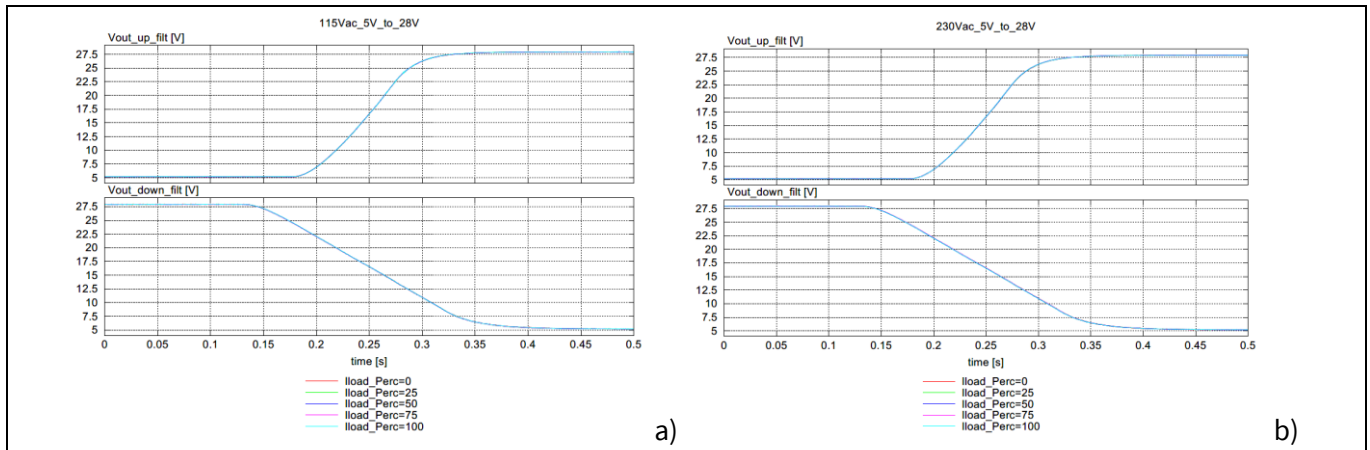

Figure 20 Output voltage transition between 5 V and 28 V: a) 115 V AC and b) 230 V AC

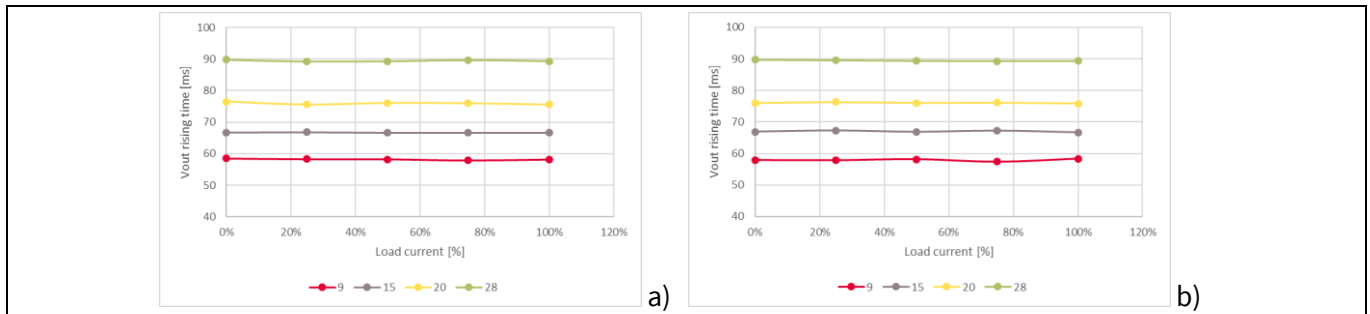

Figure 21 Output voltage rising time from 5 V to other voltage levels: a) 115 V AC and b) 230 V AC

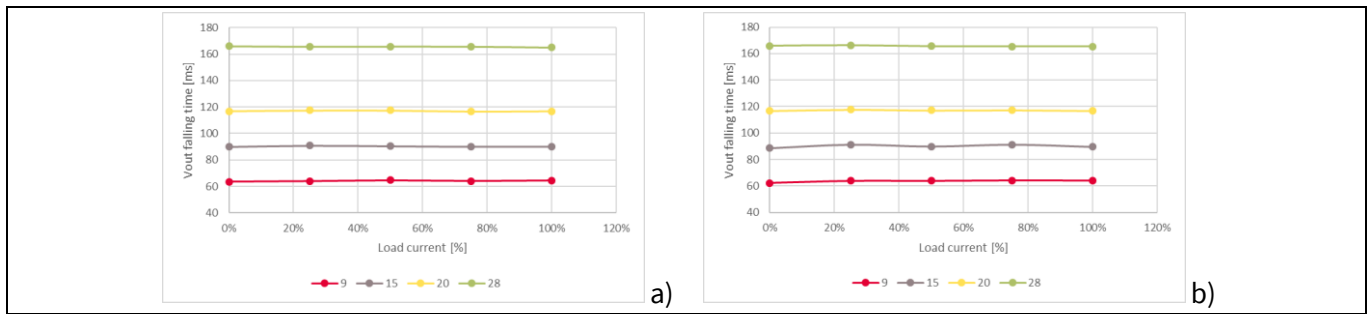

Figure 22 Output voltage falling time from other voltage levels to 5 V: a) 115 V AC and b) 230 V AC

Output voltage ripple at different conditions is shown in [Figure 23](#).

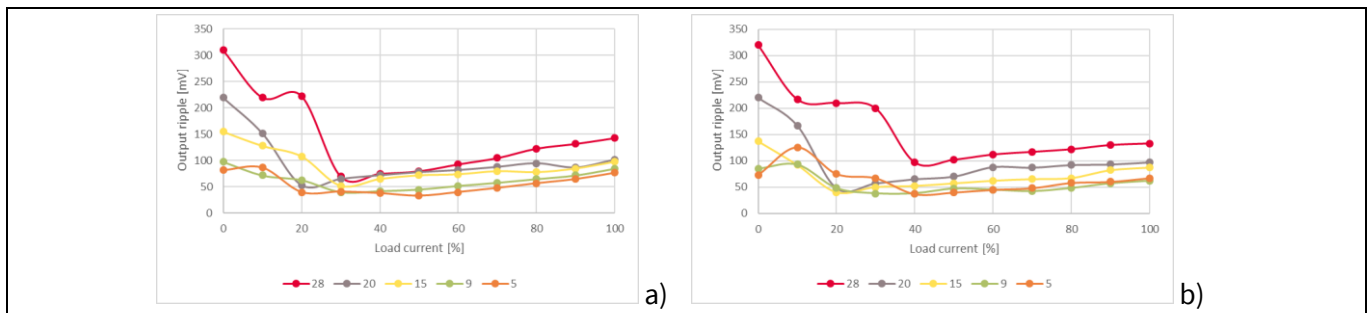

Figure 23 Output ripple measured at Type-C connector: a) 115 V AC and b) 230 V AC

System performance

3.5 System performance

3.5.1 Efficiency and standby power

Efficiency of the board measured at the Type-C connector is shown in [Table 7](#).

Table 7 Efficiency as a percentage, measured at the Type-C connector

V_{AC} [V]	V_{out} [V]	I_{out}			
		100%	75%	50%	25%
115	5	89.04	89.17	87.84	84.40
	9	92.19	92.04	90.53	87.37
	15	93.22	93.65	92.87	89.23
	20	93.54	93.57	92.56	88.77
	28	93.51	93.35	92.25	87.93
230	5	89.89	89.60	87.74	84.62
	9	93.04	92.50	90.35	87.93
	15	93.94	94.71	93.83	90.09
	20	94.59	94.35	92.97	89.09
	28	94.92	94.48	93.17	89.17

These results are illustrated in the [Figure 24](#).

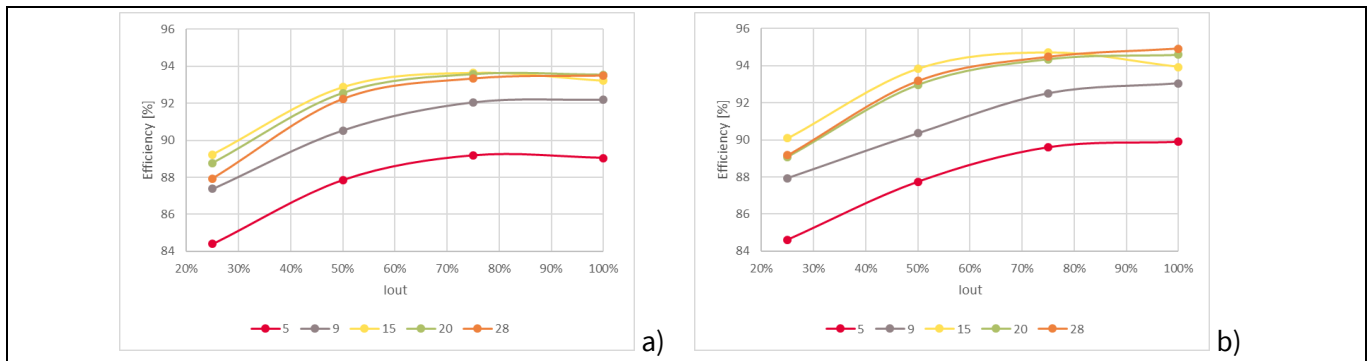

Figure 24 Efficiency measured at the Type-C connector: a) 115 V AC and b) 230 V AC

Average efficiency of the board measured at the Type-C connector is shown in [Table 8](#) and illustrated in [Figure 25](#).

Table 8 Average efficiency as a percentage, measured at the Type-C connector

V_{out} [V]	V_{AC} [V]	
	115	230
5	87.61	87.96
9	90.53	90.96
15	92.24	93.14
20	92.11	92.75
28	91.76	92.94

System performance

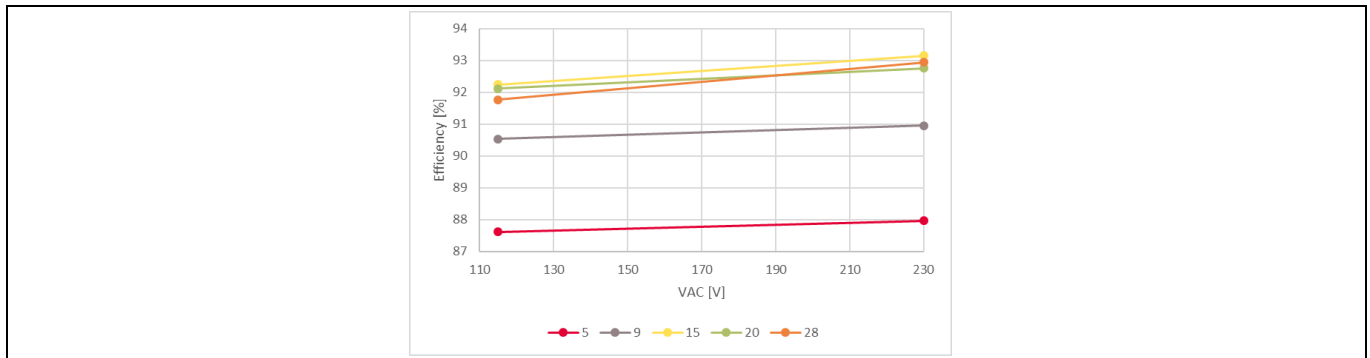

Figure 25 Average efficiency measured at the Type-C connector

System standby input power is measured, and the results are shown in Figure 26. For this measurement, the EPR daughter board is disconnected.

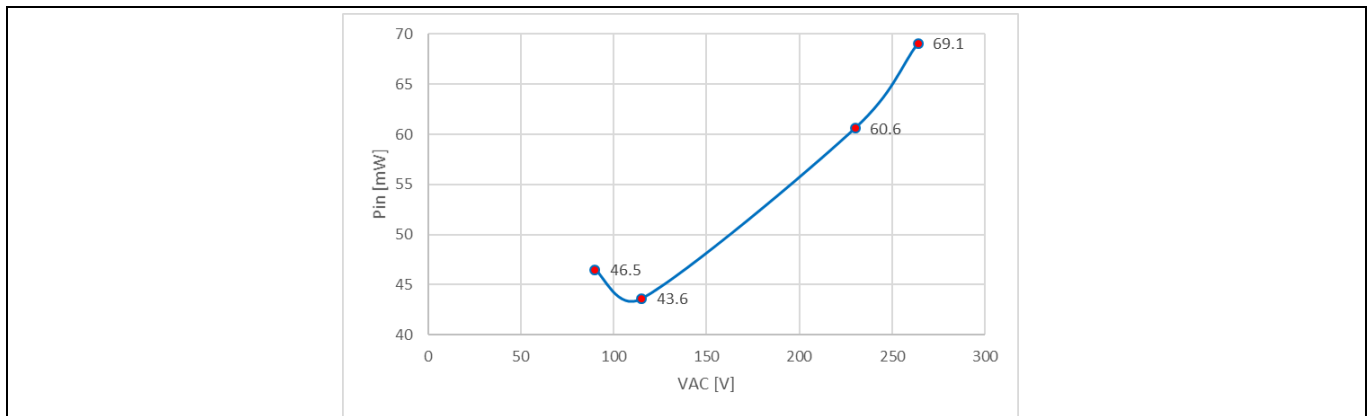
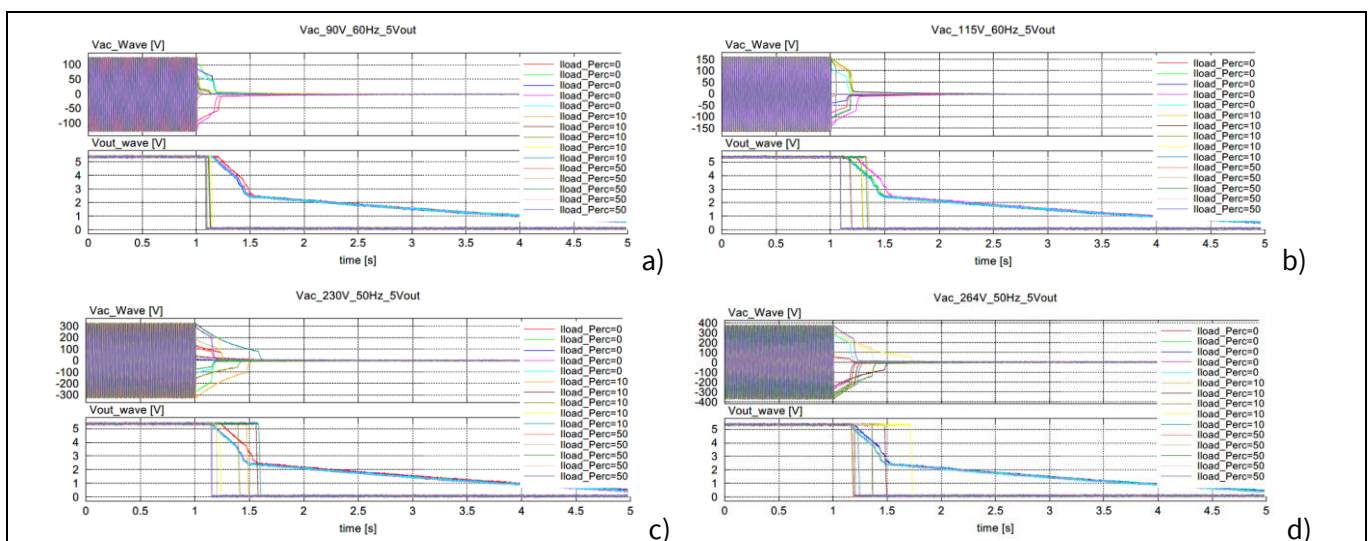

Figure 26 Standby input power measurement with EPR board disconnected

3.5.2 X-capacitor discharge

The X-capacitor discharge function is integrated and some test results under different conditions are shown in Figure 27. Under all conditions, the X-capacitor voltage is discharged below 60 V within 1 s.



(figure continues...)

System performance

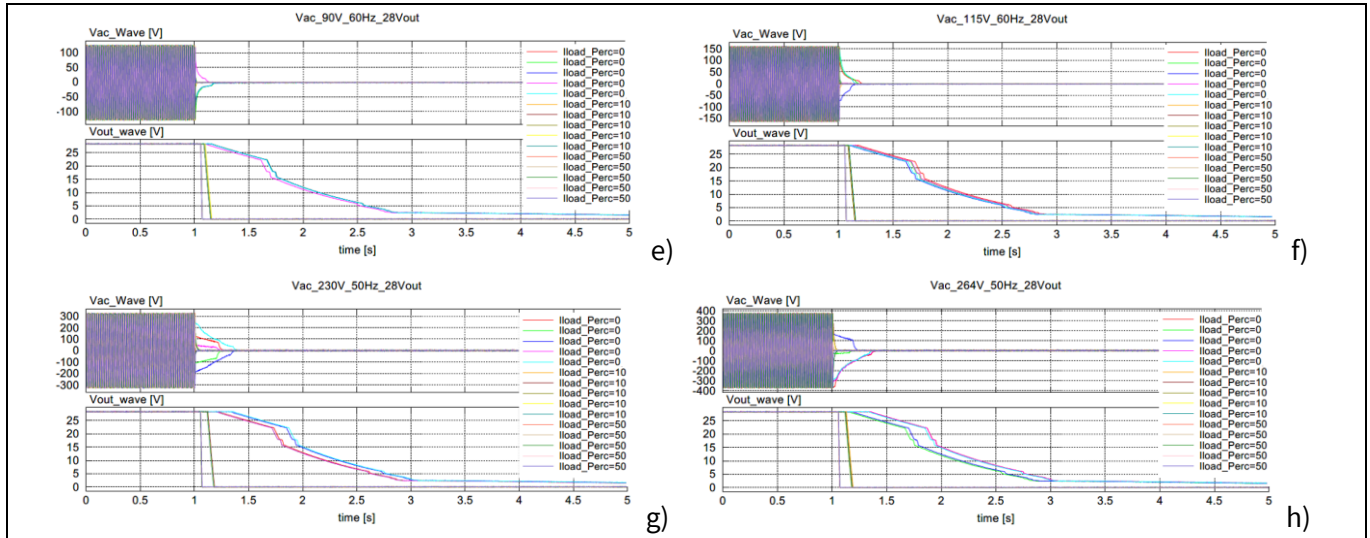
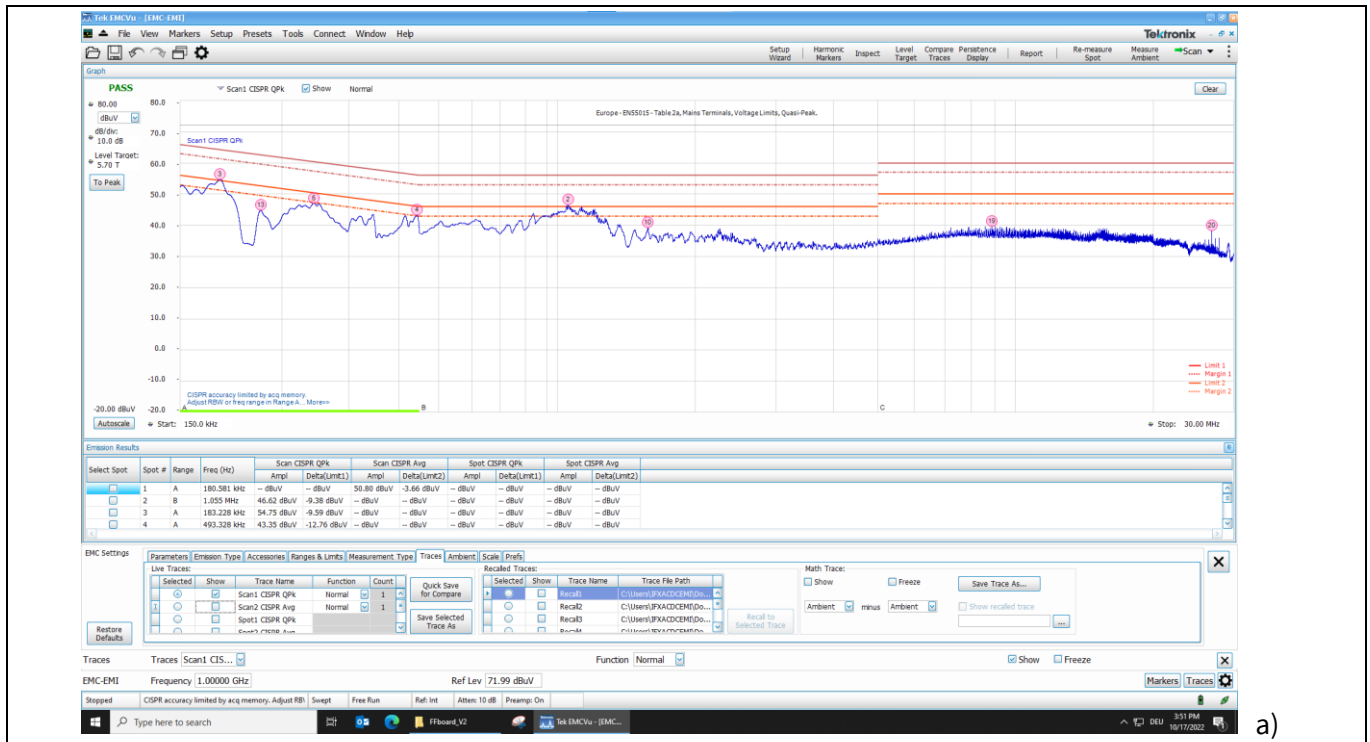

Figure 27 X-capacitor discharge

3.5.3 EMI

The EMI quasi-peak measurement of the board is shown in **Figure 28**. The upper red lines show the quasi-peak limit and the dashed lines below show the -3 dBμV margin. As the results show, better than -3 dBμV is achieved.



(figure continues...)

140 W USB-PD reference board with PFC + hybrid flyback combo IC

XDP™ XDPS2221

System performance

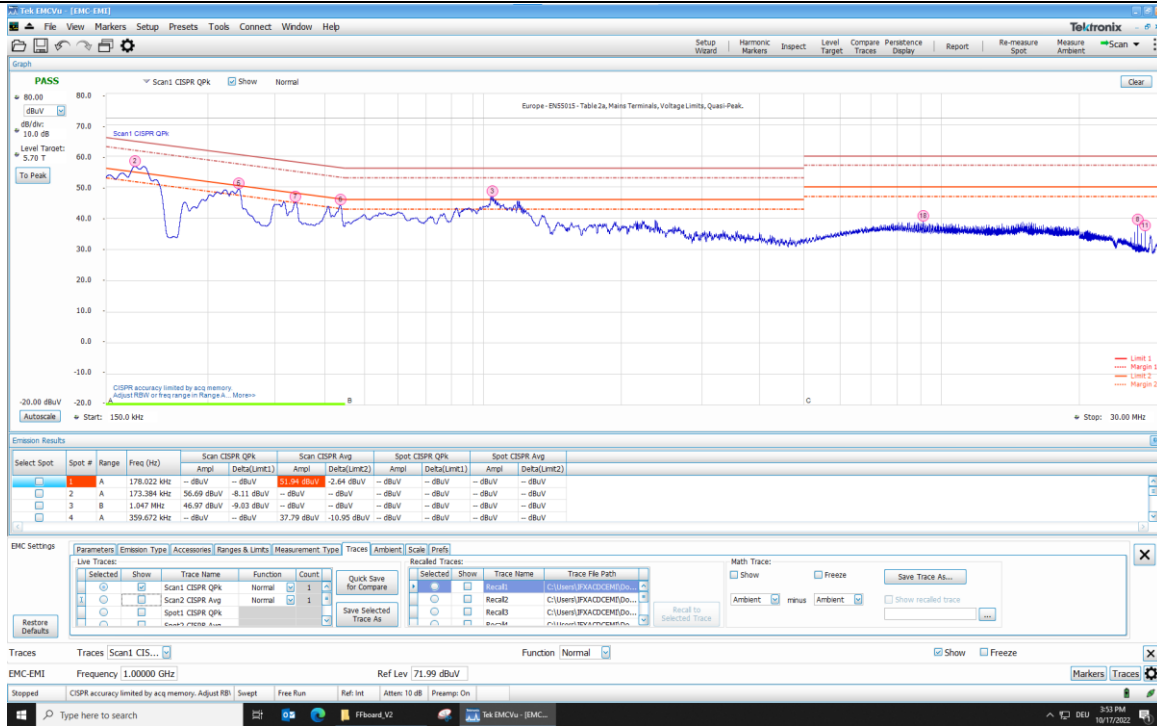

b)

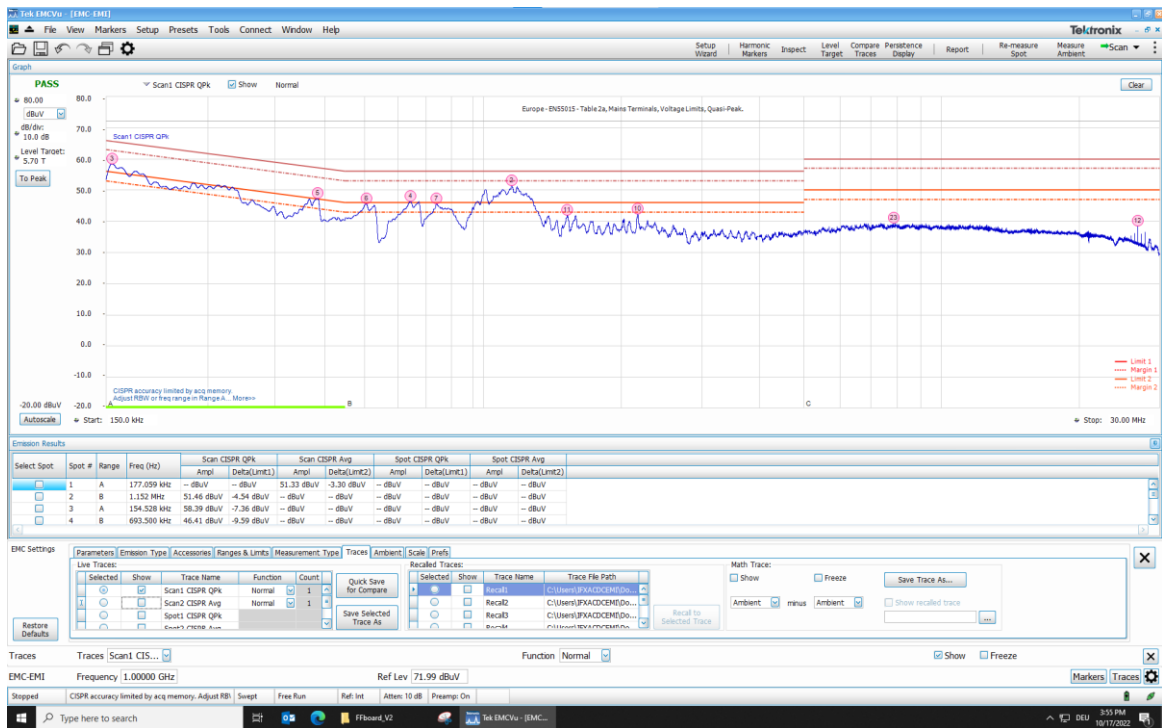

c)

(figure continues...)

140 W USB-PD reference board with PFC + hybrid flyback combo IC XDP™ XDPS2221



System performance

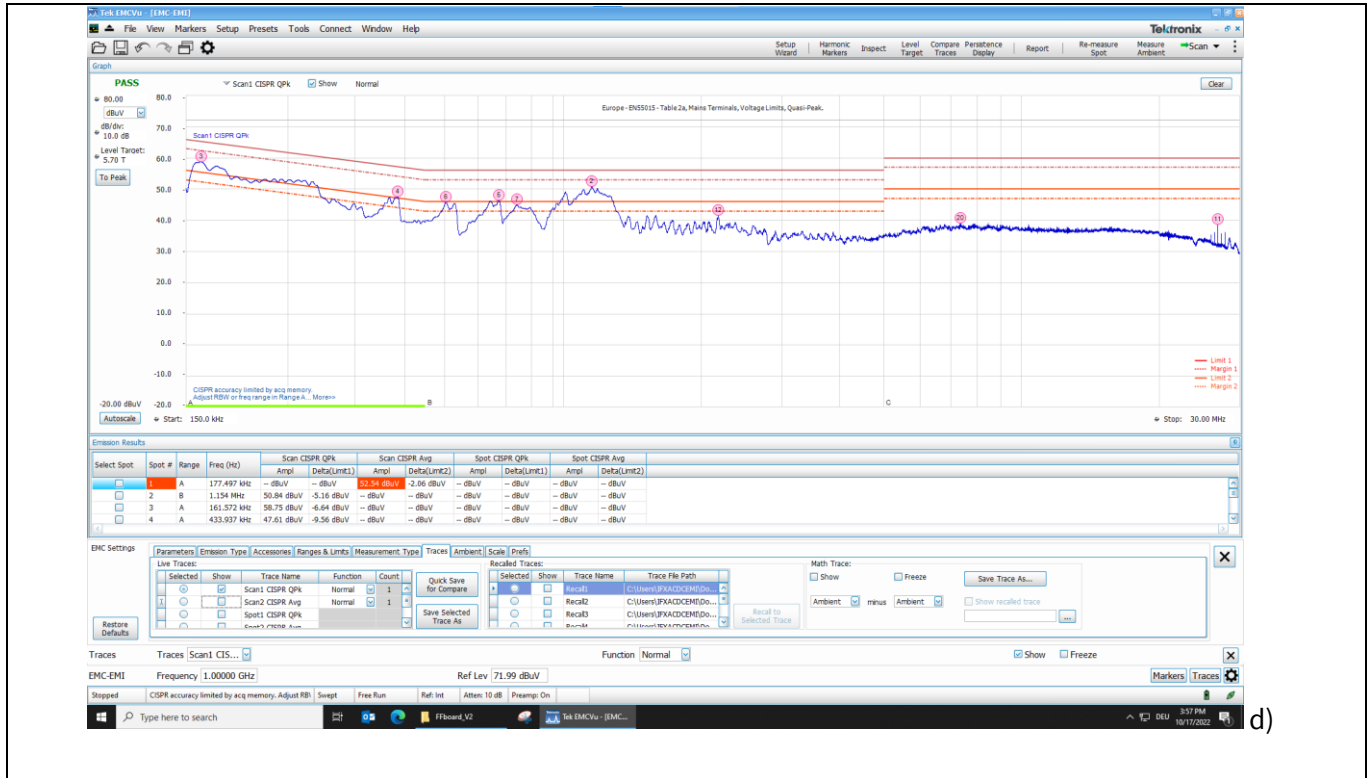
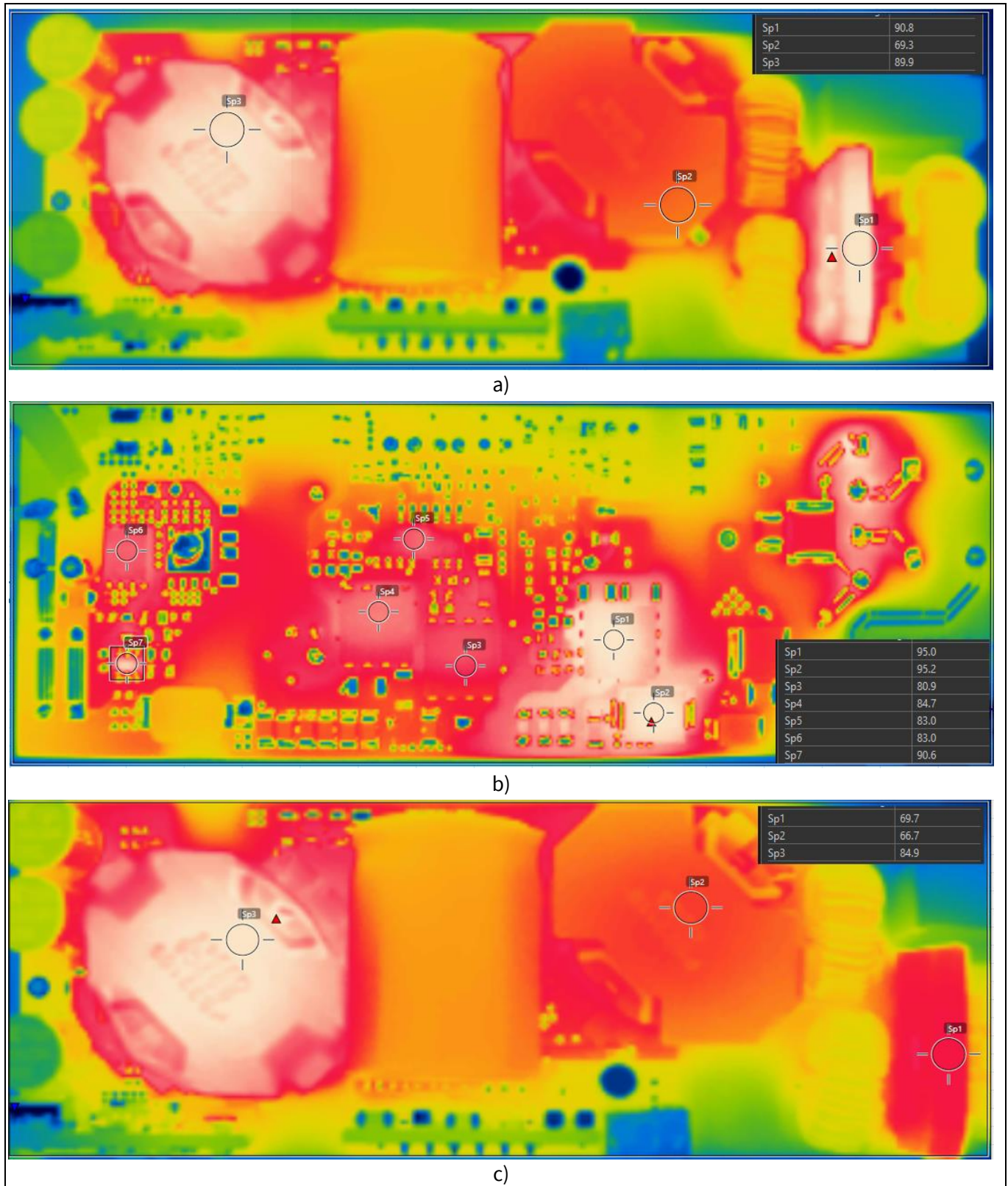

Figure 28 Conducted EMI measurement: a) line at 115 V and full load, b) neutral at 115 V and full load, c) line at 230 V and full load and d) neutral at 230 V and full load

System performance

3.5.4 Thermal measurement

The following images in **Figure 29** are the thermal images of the board at full load.



(figure continues...)

System performance

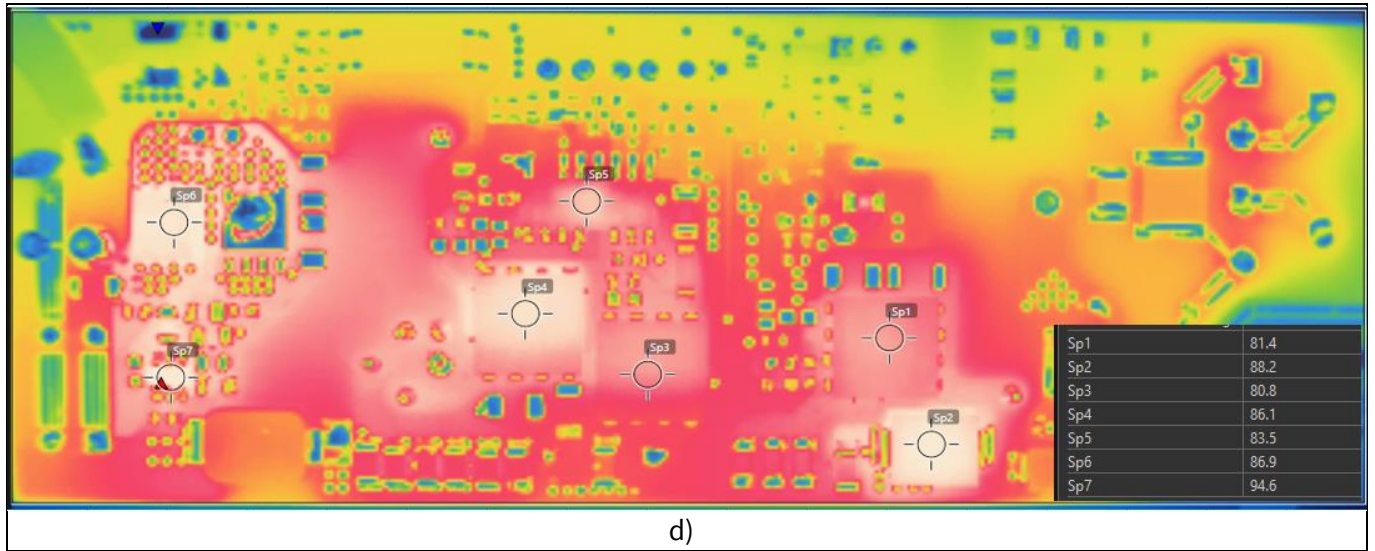

Figure 29 Thermal measurement: a) top side at 115 V AC, b) bottom side at 115 V AC, c) top side at 230 V AC and d) bottom side at 230 V AC

The measurements show that the device with the highest temperature captured on the board is the PFC diode at 115 V AC and full load, reaching a temperature of 95.2°C.

Appendices

4 Appendices

The chapter presents the following information:

- BOMs of the boards
- Information on the magnetic devices

4.1 Bills of materials of the boards

In this sub-chapter, BOMs of the three boards are given. While the given component voltage class shows its required operating voltage, some components on the board may have higher specification values due to component availability. Unless otherwise indicated in the BOM, 5 percent or better tolerance applies to the standard SMD resistors, and X7R or better or higher voltage class applies to the standard ceramic capacitors.

Table 9 BOM of the main power board

No.	Quantity	Designator	Description
1	1	C100	47 pF, 6.3 V, 0603
2	1	C101	3.3 nF, 6.3 V, 0603
3	3	C102, C300, C301	3.3 nF, 25 V, 0603
4	2	C105, C107	100 nF, 450 V, 1206
5	1	C106	82 µF, 450 V, United Chemi-Con, EKXL451ELL820MM25S
6	1	C200	220 pF, 6.3 V, 0603
7	2	C201, C207	100 nF, 25 V, 0603
8	1	C202	1 µF, 25 V, 0603
9	1	C203	10 pF, 6.3 V, 0603
10	1	C204	100 pF, 6.3 V, 0603
11	1	C206	22 µF, 25 V, THT
12	1	C208	150 pF, 6.3 V, 0603
13	1	C209	22 pF, 6.3 V, 0603
14	6	C210, C211, C212, C213, C222, C223	100 nF, 250 V, 1206, X7R, 10%, Yageo, CC1206KKX7RYBB104
15	1	C215	22 µF, 35 V, 1206
16	3	C216, C219, C221	330 µF, 35 V, Kemet, A750KW337M1VAAE020
17	1	C217	100 pF, 35 V, 603
18	1	C218	100 nF, 35 V, 0603
19	1	C220	1 nF, 50 V, 0603
20	1	C400	1 µF, 25 V, 0805
21	1	C402	100 nF, 35 V, 0603
22	2	CB100, CB102	470 nF, 630 V, 2220
23	2	CB101, CB103	220 nF, 450 V, 1210
24	1	CX100	330 nF, 275 V
25	1	CY200	470 pF, 2220
26	1	D100	GBU8K, THT
27	2	D101, D102	US1MFA, SOD-23FL

140 W USB-PD reference board with PFC + hybrid flyback combo IC XDP™ XDPS2221



Appendices

No.	Quantity	Designator	Description
28	4	D103, D104, D105, D200	1N4148WS-7-F, SOD-323
29	1	D106	RS3JB-13-F, SMB
30	1	D108	MUR560J, 600 V, SMC
31	1	D201	ES1JL, SMA
32	1	D202	ATL432LIBQDBZRQ1, SOT-23(3)
33	1	EPR_28V	USBPD_EPR_28V daughter board
34	1	F100	3.15 A, 63 V, THT
35	1	J1	JL-1000-25-T, JP-THT-JL-1000-25-T
36	1	JP200	HTSW-103-07-G-S, CON-THT-2.54-3-1-8.38
37	1	LC100	12 mH, THT, ItaCoil SCF1515050
38	2	LD100, LD101	60 µH, THT, Würth Elektronik 7447023
39	3	Q100, Q300, Q301	IGLD60R190D1, PG-LSON-8-1, Infineon
40	1	Q400	BSC040N10NS5, PG-TDSON-8, Infineon
41	1	R100	24k, 200 V, 1206
42	1	R101	27k, 200 V, 1206
43	1	R102	0 R, 1206
44	1	R103	9.1k, 150 V, 0805
45	4	R104, R206, R218, R223	0 R, 0603
46	1	R105	68k, 75 V, 0603
47	3	R106, R303, R305	39 R, 75 V, 0603
48	3	R107, R302, R304	1.5k, 50 V, 0603
49	2	R109, R205	18k, 75 V, 0603, 1%
50	1	R110	33k, 75 V, 603
51	3	R111, R112, R114	300 mR, 1206, 1%
52	1	R200	750k, 75 V, 0603, 1%
53	1	R201	150k, 75 V, 0603, 1%
54	2	R202, R203	10 MEG, 500 V, 1206, 1%
55	1	R204	6.8k, 75 V, 0603, 1%
56	1	R209	3.3 R, 200 V, 1206
57	2	R210, R220	1k, 75 V, 0603
58	2	R211, R212	330 mR, 1206, 1%
59	1	R214	4.7 MEG, 400 V, 1206
60	1	R215	100 R, 150 V, 0805
61	1	R216	1.1k, 75 V, 0603, 1%
62	1	R217	8.2k, 75 V, 0603
63	1	R219	4.7k, 75 V, 0603
64	2	R221, R222	240k, 75 V, 0603, 1%
65	2	R306, R307	22k, 75 V, 0603

140 W USB-PD reference board with PFC + hybrid flyback combo IC XDP™ XDPS2221



Appendices

No.	Quantity	Designator	Description
66	2	R400, R401	5.1 R, 150 V, 0805
67	1	R403	100k, 150 V, 0805
68	1	R404	510 R, 150 V, 0805
69	2	R405, R406	10k, 75 V, 0603
70	1	RV100	TVS 275 V AC, THT
71	1	T100	180 μ H; Np:Naux = 46:8, RM10, 3C95, Sumida PS22109, see Figure 30 and Figure 31
72	1	T200	Np:Ns:Naux1:Naux2 = 21:3:1:2, RM10, 3C95, Lp 220 μ H, Llk 2.8 μ H, RM10; Sumida PS22110, see Figure 32 and Figure 33
73	1	U200	XDPS2221, DSO-14, Infineon
74	1	U201	TCLT1003, SOP4L
75	1	U400	MP6908GJ, TSOT-23-6
76	1	Z100	Zener 2.7 V, SOD-323
77	0	C103, C302, C303	
78	0	C104	
79	0	C205	
80	0	C304	
81	0	C401	
82	0	C407	
83	0	D107, D300, D301	
84	0	Q401	
85	0	R108	
86	0	R113	
87	0	R207	
88	0	R208	
89	0	R213	
90	0	R300, R301	
91	0	R308	
92	0	R402	
93	0	RX100, RX101	

Table 10 BOM of the V_{cc} board

No.	Quantity	Designator	Description
1	4	C500, C501, C504, C505	470 nF, 100 V, 1206
2	4	C502, C506, C507, C508	4.7 μ F, 100 V, 1206
3	1	C503	1 μ F, 50 V, 0805
4	2	D500, D501	SS28L, SOD-123F-2
5	2	D502, D503	PMEG4010BEA, 115
6	1	Q500	BSS169, PG-SOT-23, Infineon
7	2	R500, R505	6.8 R, 200 V, 1206

140 W USB-PD reference board with PFC + hybrid flyback combo IC XDP™ XDPS2221



Appendices

No.	Quantity	Designator	Description
8	2	R501, R506	0 R, 1206
9	1	R504	47k, 75 V, 0603
10	1	X500	6-pin header, 2.54 mm
11	1	Z500	BZT52-B10J, 10 V, SOD-123

Table 11 BOM of the EPR board

No.	Quantity	Designator	Description
1	1	C1	100 nF, 35 V, 0603
2	2	C2, C4	2.2 μ F, 35 V, 0603
3	1	C3	2.2 μ F, 6.3 V, 0603
4	4	C5, C6, C11, C12	1 μ F, 6.3 V, 0603
5	2	C7, C10	100 nF, 6.3 V, 0603
6	2	C8, C9	390 pF, 50 V, 0603
7	2	D2, D3	1N4148WS, SOD-323
8	1	ESD1	ESDA25L, SOT-23-3L
9	1	G1	MCP1799-500, SOT-223
10	2	Q2, Q2A	IRLML6402TRPBF, SOT-23
11	3	Q3, Q4, Q5	2N7002, SOT-23
12	1	Q6	IRF7240, SO-8
13	1	R1	51k, 75 V, 0603
14	2	R2, R4	100 R, 200 V, 1206
15	2	R3, R11	100k, 75 V, 0603
16	2	R7, R8	100k, 75 V, 0603, 1%
17	1	R5	1 MEG, 50 V, 0603
18	1	R9	22k, 150 V, 0805
19	2	R12, R13, R14	10k, 75 V, 0603
20	2	R15, R16	10k, 75 V, 0603, 1%
21	2	R17, R18	10 mR, 0805, 1%
22	1	R19	1k, 75 V, 0603
23	1	U1	CYPD3175-24LQXQ, QFN-24, Infineon
24	1	X1	USB Type-C connector, JAE, DX07S016JA3R1500

Appendices

4.2 Information on the magnetic devices

Information about the PFC choke and the HFB transformer is shown in **Figure 30** to **Figure 33**.

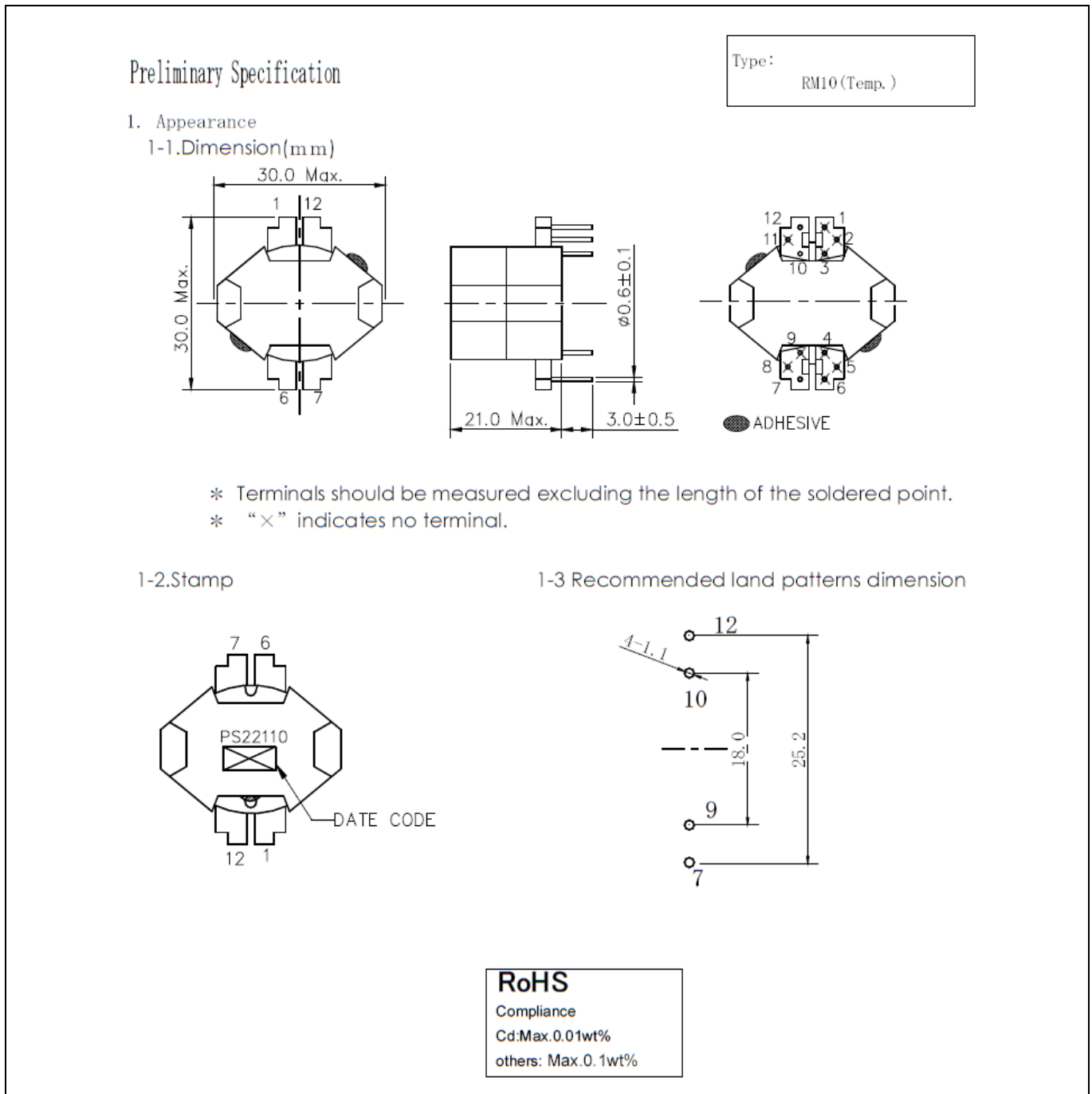

Figure 30 PFC choke PS22110: part 1

Appendices

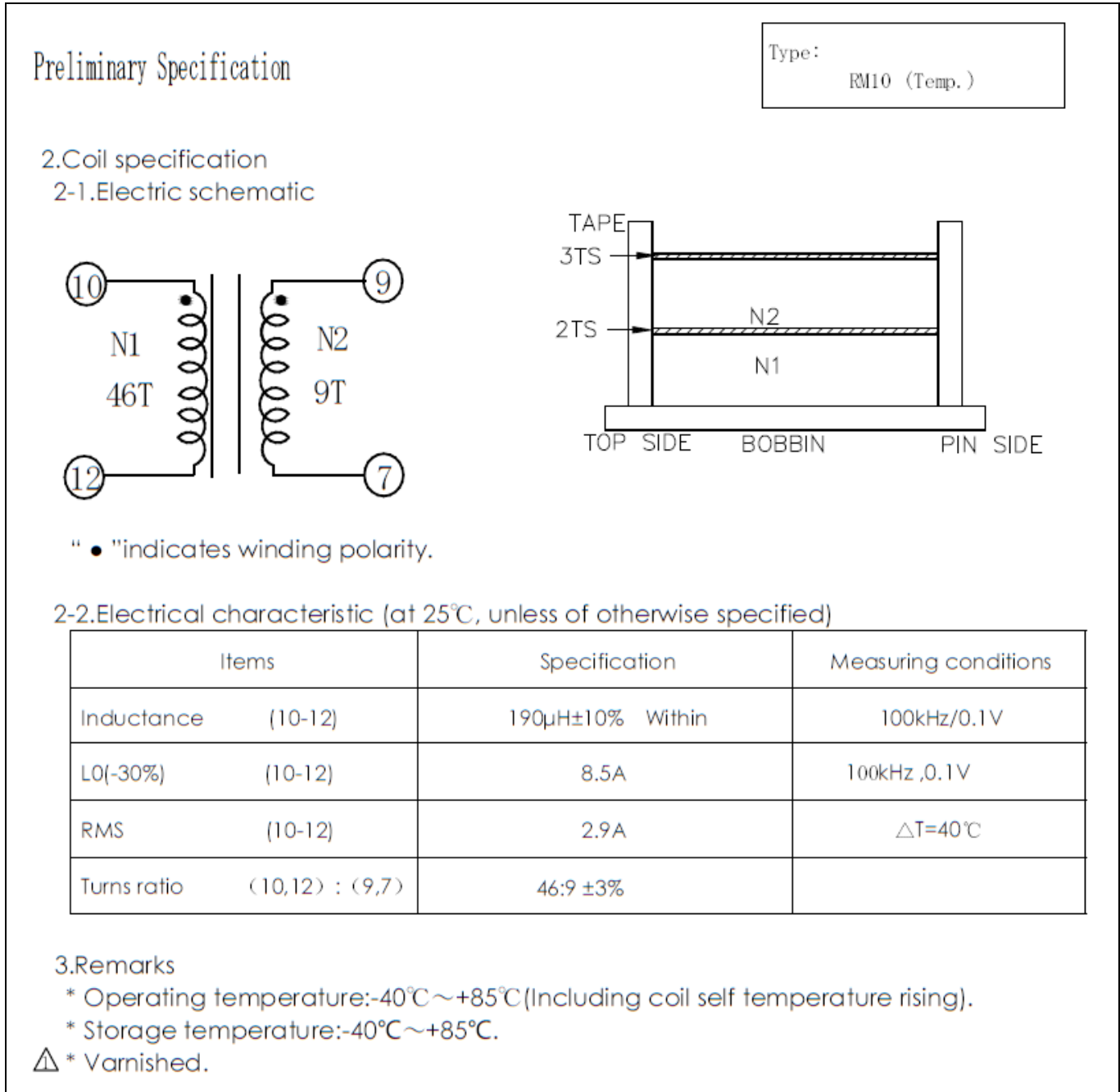

Figure 31 PFC choke PS22110: part 2

Appendices

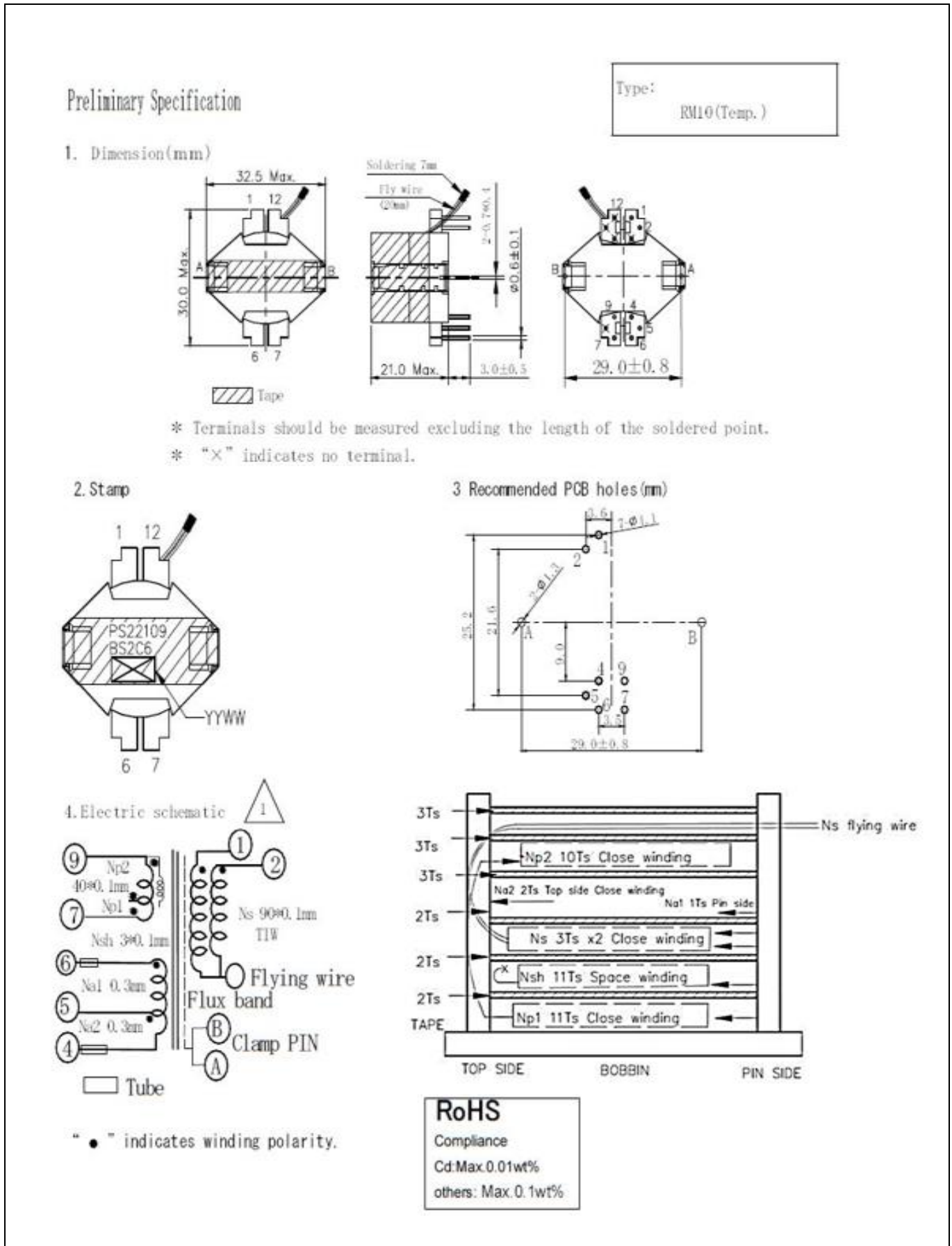

Figure 32 HFB transformer PS22109: part 1

Appendices

Preliminary Specification

Type: RM10 (Temp.)

5. Electrical characteristic (at 25°C, unless of otherwise specified)

Items	Specification	Measuring conditions
Inductance (9-7)	230 μH ± 10% Within	150kHz/0.1V 0A
Inductance drop (9-7)	≅ 35% L0	150kHz, 0.1V 3.4A
Rated current (9-7)	1.4Arms	ΔT=40°C
Rated current (1, 2-Fly)	8.3Arms	ΔT=40°C
Hi-Pot (9, 7, 6, 5, 4) - (1, 2, Fly)	AC 3000Vrms	50/60Hz, 1mA, 2s
Hi-Pot Coil-Core	AC 500Vrms	50/60Hz, 1mA, 2s
Hi-Pot (9, 7) - (6, 5, 4)	AC 500Vrms	50/60Hz, 1mA, 2s
Turn ration (Np:Ns:Na1:Na2)	21:3:1:2 ± 3%	

6. The materials according to OBJY2 E176884 system designation 130(B) BS2, SBI4.2.

No.	Part name	Material description	Manufacture Factory	UL File No.
①	Bobbin	Phenolic resin PM9630 or PM9820	SUMIMOTO BAKELITE CO., LTD	E41429
②	Core	Ferrite Core 3C95 or TPW33 or HE6	FERROXCUBE TDG HOLDING CO., LTD HEC	N/A
③	wire	TIW (e0. 1*90 Triple insulated Litz wire)	E&B TECHNOLOGY CO LTD	E315265
		Litzwire (e0. 10*40) MW75C or MW 79-C	EASEBOND ELECTRICAL MATERIAL (DONGGUAN) CO., LTD BAIYIN YIZHI CHANGTONG SUPER MICRO. WIRE CO., LTD	E173779 E363385
		Enameled copper wire MW 79-C or MW 80-C or MW 82-C or MW 83-C	JUNG SHING WIRE CO., LTD. TAI-I COPPER (GUANGZHOU) CO., LTD SAINT (SHANGDONG) ELECTIRC CO., LTD	E174837 E234896 E194410
④	Clip	Material SK7	PIN SGINE ELECTRIC CO., LTD or etc.	N/A
⑤	Terminal	Phosphor bronze	Various	N/A
⑥	Glue	Epoxy	NAGASE CHEMTEX CORPRATION	N/A
⑦	Interlamination insulation tape	1318 or CT280 or CT281	3M COMPANY HUIZHOU YAHUA STICKING TAPE CO., LTD	E17385 E495875
		Adhesive copper tape CP-3002	JINGJIANG YAHUA PRESSURE SENSITIVE GLUE CO., LTD	E165111
⑨	Tubing	CB-TT-L	CHANGYUAN ELECTRONICS GROUP CO LTD	E180908

7. Remarks

* Operating temperature: -40°C ~ +125°C (Including coil self temperature rising).

* Storage temperature: -40°C ~ +125°C.

Figure 33 HFB transformer PS22109: part 2

References

References

- [1] Infineon Technologies AG: XDPS2221 PFC + hybrid flyback – combo controller, Datasheet (Rev. 1.0); 2022-10-13; [available online](#).

Revision history

Document version	Date	Description of changes
V 1.0	2022-11-11	Initial release
V 1.1	2022-12-12	Figure 32 updated

Trademarks

All referenced product or service names and trademarks are the property of their respective owners.

Edition 2022-12-12

Published by

Infineon Technologies AG

81726 Munich, Germany

© 2022 Infineon Technologies AG.

All Rights Reserved.

Do you have a question about this document?

Email: erratum@infineon.com

Document reference

ER_2209_PL21_2210_154134

Important notice

The information contained in this application note is given as a hint for the implementation of the product only and shall in no event be regarded as a description or warranty of a certain functionality, condition or quality of the product. Before implementation of the product, the recipient of this application note must verify any function and other technical information given herein in the real application. Infineon Technologies hereby disclaims any and all warranties and liabilities of any kind (including without limitation warranties of non-infringement of intellectual property rights of any third party) with respect to any and all information given in this application note.

The data contained in this document is exclusively intended for technically trained staff. It is the responsibility of customer's technical departments to evaluate the suitability of the product for the intended application and the completeness of the product information given in this document with respect to such application.

Warnings

Due to technical requirements products may contain dangerous substances. For information on the types in question please contact your nearest Infineon Technologies office.

Except as otherwise explicitly approved by Infineon Technologies in a written document signed by authorized representatives of Infineon Technologies, Infineon Technologies' products may not be used in any applications where a failure of the product or any consequences of the use thereof can reasonably be expected to result in personal injury.